

## Design Optimization of Single Axis Thrust Magnetic Bearing Actuator

Dash S K\* and Shanti Swarup K\*

*Design optimization of Active Magnetic Bearing (AMB) is important from the point of view of reliable and high speed operation. They are widely used in fly wheels, wind generators, high temperature applications, etc. Design and development of large air gap AMB is a challenge, This paper presents the modeling and design optimization of a large air gap AMB using open loop position stiffness. In this work, a goal seeking optimization methodology is employed for double acting AMB system where a combination of higher (CRGO electrical steel) and lower saturating magnetic material (Mu metal) is used. Adaptive Response Surface Method (ARSM) was used as a tool for optimization. A less variant position stiffness across 1500 microns air gap was arrived at after getting optimized design variables constituting geometry and excitation current parameters using above comprehensive optimization method. This investigation opens up a new way to attain position stiffness in AMB system which is less sensitive to positional variation of rotor in air gap.*

**Keywords:** Thrust Magnetic Bearing, Position Stiffness, Goal Driven Optimization

### 1.0 INTRODUCTION

Magnetic bearings and Ferro-fluid seal are being developed to be used in primary sodium pumps in Sodium cooled Fast Reactors to replace mechanical bearings and seals. Over the past few decades, great developments have been made in the field of advanced bearings [1][2][3][4]. Bearings aimed at supporting high-speed flexible rotors in adverse and hostile environment found in new rotating machinery applications and magnetic bearings are emerging as a promising solution to meet these demanding requirements sought in these applications.

Typical Configuration of Active Magnetic Bearing used in any kind of application is shown in Figure 1 and Figure 2.

The magnetic bearing consists of electromagnetic actuators powered by controlled power source along with rotating parts of shaft. Normally,

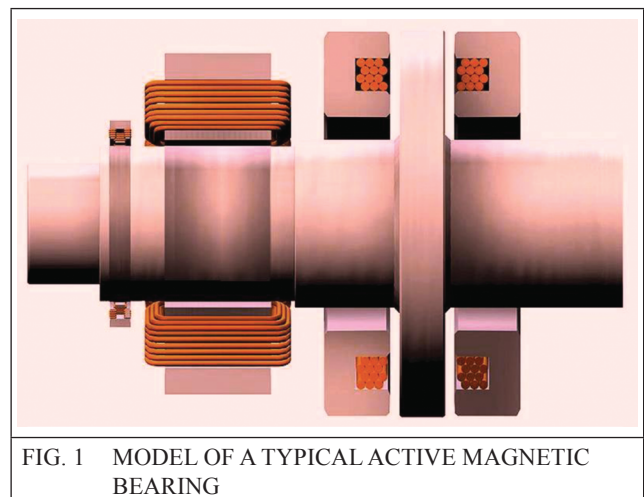

FIG. 1 MODEL OF A TYPICAL ACTIVE MAGNETIC BEARING

deployed active magnetic bearings always associated with sophisticated control system hardware, both analog and digital, to control the gap between the rotating shaft and static magnetic actuators. The sophisticated control effort is crucial due to the fact that the Force-Current-Gap relationship is highly non-linear. The magnetic actuator with differential drive with

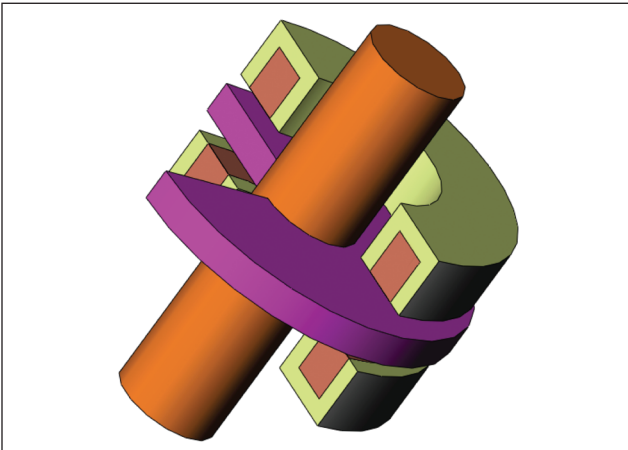

FIG. 2 AXIAL MAGNETIC BEARING

bias and controlling current, which makes the force-current-gap relationship less non-linear, still demands good amount of sophisticated feedback controlling effort. The inherent drift behaviors of electronic component render the magnetic bearing sometimes unreliable in hostile environment like in harsh reactor ambience. Challenge posed by fast reactor centrifugal pump shaft is the thermal expansion. As the magnetic bearing known to work in low tolerance dimensional regime, it is very tricky to implement even state-of-the-art magnetic bearing for this purpose where the operating parameter necessitates introduction of large air gaps.

## 2.0 LITERATURE REVIEW

The recognition goes to Jesse Beams [5] of University of Virginia as the father of magnetic bearing. Various optimal designs of magnetic actuator suggested by Jaggu S rao et al [6] towards minimizing power loss and self weight. David Meeker [7] suggested Optimal solutions towards lower power loss by direct optimal approach with lot of mathematical treatment. His works laid lot of emphasis on slew rate limits. Cheng et al [8] suggested optimization of Hybrid Magnetic Bearing for increase in positional and current stiffness. Gruber et al [9] used stator pole parameter optimization of Permanent magnet biased rotor having larger air gap. Thomas Reichert et al [10] discussed permanent magnet biased bearing less Permanent Magnet Synchronous

Motor for large air gap application. Nguyen et al [11] used parameter optimization of Axial Flux Permanent Magnet Machine to reduce axial bearing stress and losses. Han Bangcheng[12] discussed sensitiveness of positional stiffness and suggested method to mitigate by using Permanent magnet biased RMB in magnetic structure. Sunghoon Lim and Seungjae Min et al [13] used multi phase level-set model and used multi-material concept for maximizing EM force with set volume constraint of permanent magnet. Lailiwang[14] used multi-permeability material with distributed air gap to increase inductance without increasing the volume. Saling et al [15] highlighted the importance of probabilistic Design in avoiding rare event phenomena by computing failure analysis. Duan et al in their review[16] highlighted the role of differential evolution (DE) for Electromagnetic problem, but, A Qing et al [17] found that though it shows the great promise in Electromagnetism because of its natural advantage over deterministic optimization algorithm, its application in Electromagnetism is seriously lagging behind application in other fields. Thus, as a tool, DE is not matures enough compared to established Genetic Algorithm and Evolution strategy. Wang et al [18] formulated Adaptive Response Surface Method (ARSM) which is robust and fast global optimization method compared to any other method. Kunakote et al [19] established the superiority of real coded ES over classic gradient based approach in topology optimization. Beyer and Schwefel [20] made a comprehensive scheme for implementation of evolution strategy with various features of algorithm. The Pham et-al [21] used Optiy to achieve reliability and robustness of MEMS.

This work uses ARSM and ES implementation of a commercially available optimizer tool Optiy as a tool for optimization.

## 3.0 PROBLEM DESCRIPTION

As open loop position stiffness is very sensitive to working air gap, sophisticated control system is employed to limit the variation of position of suspended rotor to a few hundred microns, which

otherwise would become unstable even in close loop if the gap becomes inadvertently large. So, large gap, in the order of 1000 microns or more, necessitates flatter open loop position stiffness than that of contemporary magnetic actuators. The magnetic actuator with differential drive with bias and controlling current, which makes the force-current-gap relationship less non-linear, still demands good amount of sophisticated feedback controlling effort. The inherent drift behaviors of electronic component render the magnetic bearing sometimes unreliable in hostile environment like in harsh reactor ambience.

Another challenge posed by fast reactor centrifugal pump shaft is the thermal expansion. As the magnetic bearing known to work in low tolerance dimensional regime, it is very tricky to implement even in the state-of-the-art magnetic bearing for this purpose. Most of the reported literature uses Permanent magnet biased Hybrid Magnetic bearing to get the leverage of high energy density of Permanent Magnet. The use of Permanent magnets in proposed Magnetic bearing is forbidden for their unfavourable high temperature characteristics. Normally, when the actuators optimized for power loss and weight, the operating flux density tends to be near knee point of BH curve of core material. They also are designed to have lower gap variation. The associated static stiffness, also perpetually becomes higher resulting very less stability margin.

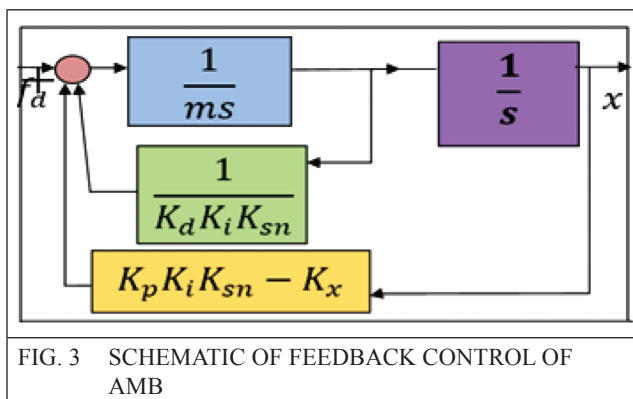

FIG. 3 SCHEMATIC OF FEEDBACK CONTROL OF AMB

Closed loop control of magnetic bearing, shown in Figure 3, though makes the bearing stable, the poles in s-plane is very sensitive to

position stiffness than current stiffness (Gerhard Schweitzer et-al[22]). Higher open loop position stiffness results in slow response to external disturbance (Akira Chiba *et al.* [23]).

#### 4.0 SCOPE OF PROBLEM

Magnetic bearings provide attractive electromagnetic suspension by application of electric current to ferromagnetic materials used in both the stationary and rotating parts of the magnetic bearing. This creates a flux path that includes both parts, and the air gap separating them, through which non-contact operation is made possible. The attractive forces generated by oppositely positioned electromagnets achieve levitation of the rotor assembly. As the air gap between these two parts decreases, the attractive forces increase, therefore, electromagnets are inherently unstable.

Figure 4 shows the two dimensional cross sectional view of Thrust actuator of AMB system. A control system is needed to regulate the current and provide stability of the forces, and therefore, position of the rotor. The present investigation deals only with single axis, axial thrust magnetic

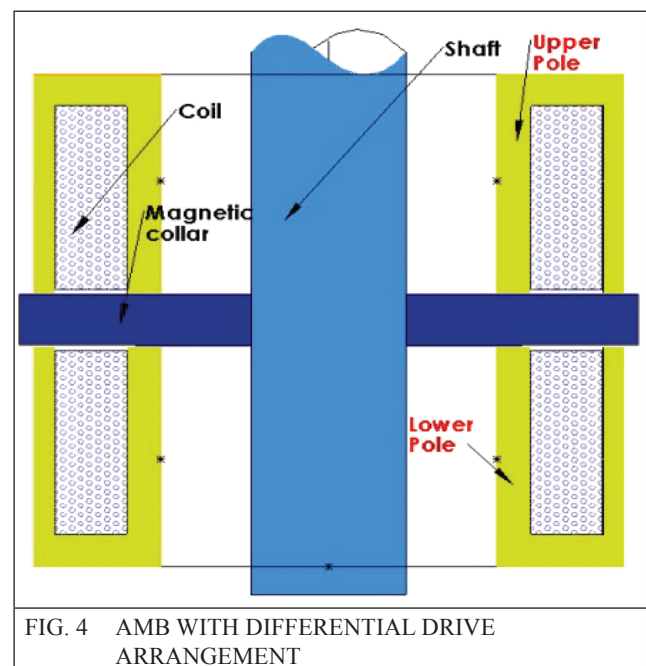

FIG. 4 AMB WITH DIFFERENTIAL DRIVE ARRANGEMENT

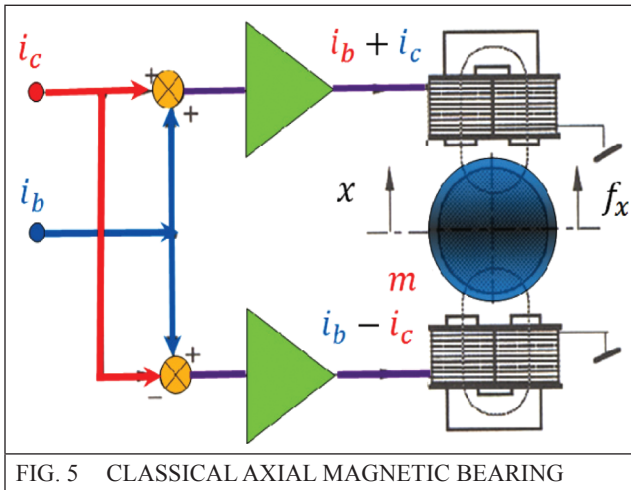

FIG. 5 CLASSICAL AXIAL MAGNETIC BEARING

Figure 5 shows the bearing with double acting actuator and differential driving mode.

**A. Design requirement of AMB**

- Static load of rotor: 300 Newton.
- Rotational speed (rpm): 3000
- Air gap: 1.5 mm (both upper and lower 0.75 mm each)
- Operating environment: room temperature.

**B. Design & Analysis of Magnetic Actuator**

The force acting on single side magnetic actuator is given by,

$$F = \frac{B_g^2 \times A}{2 \mu_0}$$

For double acting magnetic bearing, the force will be

$$F = \frac{A}{2 \times \mu_0} (B_u^2 - B_l^2)$$

F= EM force in N,

B<sub>u</sub>=Flux density in upper air gap

B= flux density in lower air gap.

A = are of air gap under the magnetic pole

For the given design specification, initial design was arrived at with a preset value inner diameter, outer diameter and height of EM actuator, as shown in Figure 4 The other design parameter (slot width, coil depth, number of turns and pole face width) were calculated (not detailed in this paper) using a Magnetic Circuit approach to

meet the Magneto Motive force requirement by actuator. The vales are listed in the Table 1.

TABLE 1			
DESIGN VALUES FOR ACTUATOR			
S. No	Description	Dimension	Re- marks
1	Rotor Collar outer diameter	159.4 mm	preset
2	Rotor Collar Inner diameter	41.7 mm	preset
3	Height of the core	65.8 mm	preset
4	Stator Core ID	90.8 mm	preset
5	rotor collar thickness	14.8 mm	preset
6	Slot width	19.3 mm	
7	Slot depth	55.4 mm	
8	Diameter of the coil conductor	1.82 mm	
9	Number of turns of coil (18 SWG) (upper magnet)	600	
9	Number of turns of coil (22 SWG) (lower magnet)	600	
10	Nominal air gap	1.5 mm	preset
11	Height of the coil	53.4 mm	
12	Depth of the coil	16 mm	
13	Core material	CRGO M19 grade, Fig. 4a	

Finite Element (FE) method is among the most useful tools for crash analysis and simulation. Electromagnetic design and optimization requires repetitive and iterative application of FE simulation.

**5.0 OPTIMIZATION METHODOLOGY**

In a innovative design problem there may be many variables, only a subset of which we can optimize. The difficulty of obtaining enough information to predict a design landscape in a hypercube of escalating dimensions (*the curse of dimensionality*) is what holds one back in terms of the number of variables we can optimize. Also taking many variables in design space may not be feasible practically from fabrication point of view. So a more reasonable design space is

defined keeping manufactur ability of actuator in consideration. During optimization, the optimizer considers the values of the design variables that evaluates the objective function subject to all the constraints and is minimum. The range of values, where all constraints are satisfied is known as permissible range. Normally, an optimization problem is formulated as

$$\begin{aligned} & \text{minimize } f(x), \\ & \text{subject to} \\ & \text{constraints} \\ & g_i(x) \leq 0, h_j(x) = 0 \end{aligned}$$

Optimization problem formulated mathematically as

$$\begin{aligned} f(x)_{target} &= K_{x(target)} * x + f_l \\ \text{Minimize error } & \text{abs} | f(x)_{target} - F_{computed} | \end{aligned}$$

Evaluated error =

$$\int_{g_{min}}^{g_{max}} \text{abs}(EMforce_{computed} - EMforce_{targeted}) dx$$

For each air-gap steps under consideration

$$f(x)_{target} = K_{x(target)} * x + f_l$$

$K_x$  = the required stiffness,

$x$  = air gap between rotor disc to lower pole of actuator

$f_l$  = EM actuator force required to be generated when armature is in lowst position.

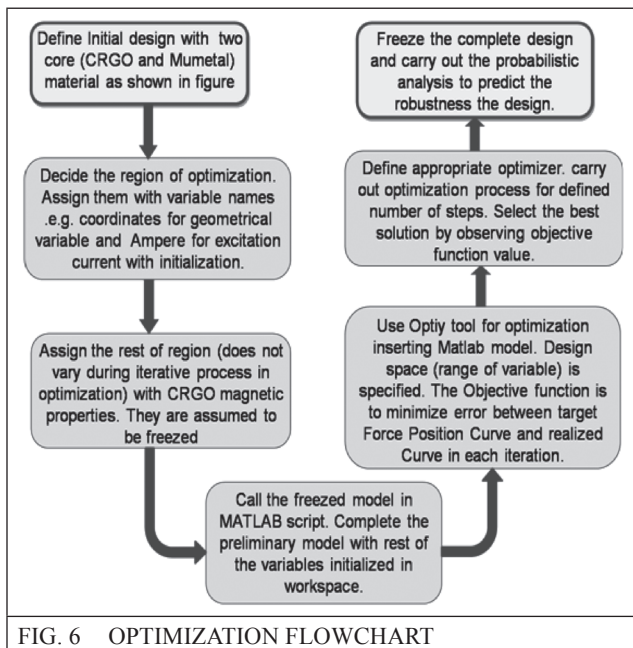

FIG. 6 OPTIMIZATION FLOWCHART

So, here objective function is basically a multi-point goal seeking function, which give multi-objective optimization character to the said problem. Figure 11 shows the flow chart for proposed optimization. Figure 7 shows the work flow in Optimizer along with MATLAB.

One of the most promising method, Evolutionary strategies are suitable for a wide band-width of optimization problems, since there are no special requirements on the objective function, such as continuity or smoothness. It is an abstraction from the theory of biological evolution that is used to create optimization procedures or methodologies. A professional Software called Optiy, which adopts Evolutionary Strategy, is used as a tool for optimization. Evolutionary strategy (ES) originally developed at Berlin Technical University by Ingo Rechenberg[24] and Hans Peter Schwefel [25].

### 6.0 OPTIMIZATION WITH DESIRED OBJECTIVE FUNCTION

There are instances of slow convergence behavior in evolutionary strategy if no. of parameters are more under certain circumstances. In this line of perspective, Adaptive response surface method is computationally cheaper as compared to the evolutionary strategies when the objective function is continuous and linear though it sometimes misses true global optimum as discussed by Wang et al [18]. But, to arrive at better parent as starting point for ES, this proves very helpful.

The portion which borders Mumetal and CRGO steel is shown double arrow (Figure 8), which would get constructed each time during iteration demanded by optimizer. The rest portion was modeled geometrically and remains unchanged (Figure 8). Figure 9 shows the pictorial depiction of variables for optimization.

Objective Function	$f(x)_{target} = K_{x(target)} * x + f_l$ <p>where <math>K_{x(target)} = 500 \frac{N}{mm}</math> and <math>f_l = 500 N</math>,</p>
--------------------	--

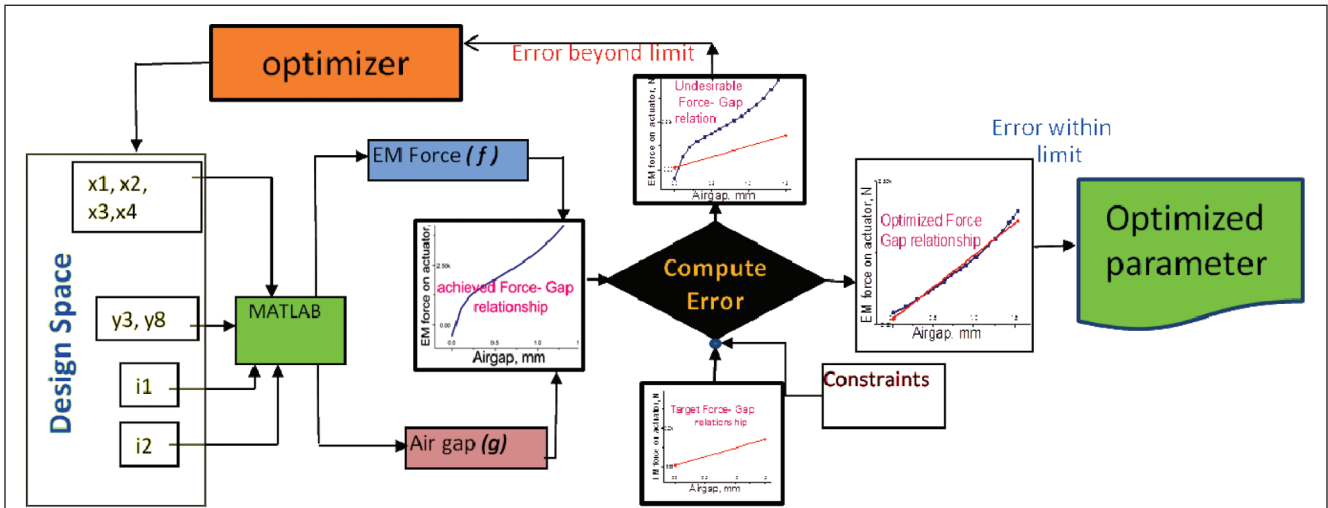

FIG. 7 PROCESS FLOW AS IMPLEMENTED IN OPTIY INTEGRATED WITH MATLAB

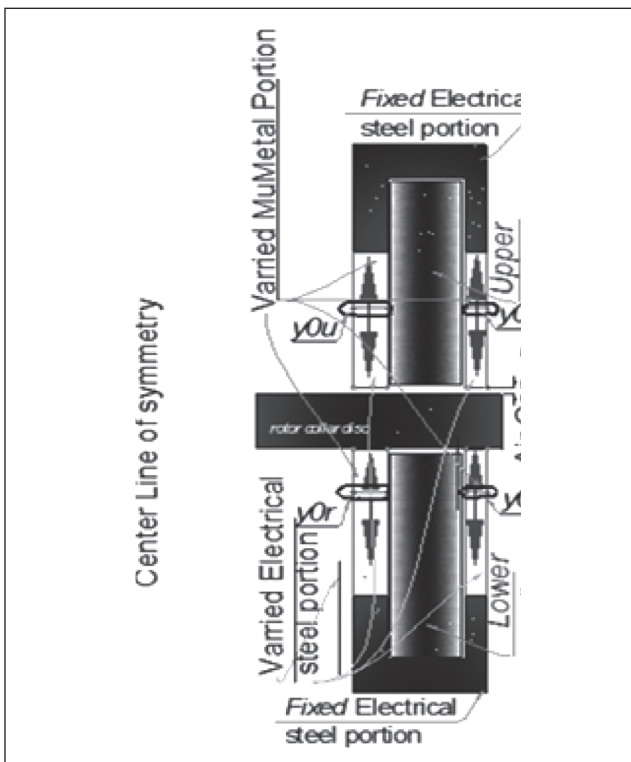

FIG. 8 PICTORIAL DEPICTION OF VARIABLES TO BE OPTIMIZED

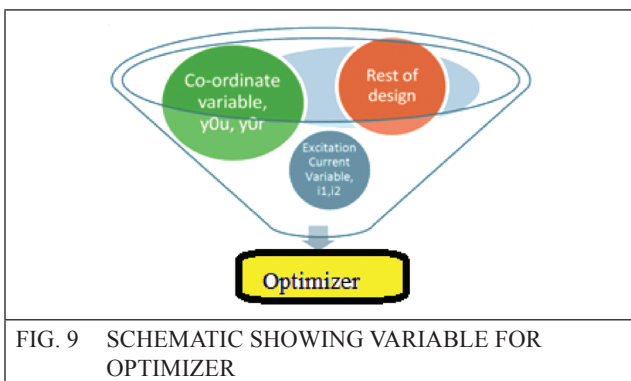

FIG. 9 SCHEMATIC SHOWING VARIABLE FOR OPTIMIZER

The adaptive response surface method (ARSM), proceed seek a solution that would combine the benefit of both in the category of gradient-based methods as well as to the global approximation. The adaptive part indicates that the Search space is gradually adjusted to a hand move-limit strategy. The parameters for optimizer is as shown in table with their nominal value and ranges. Objective function chosen as follows.

TABLE 2				
NOMINAL VARIABLE WITH RANGE				
Parameter	Description	Nominal Value	Upper Range	Lower Range
$y0u$	upper coordinate	43.8 mm	51 mm	18 mm
$y0r$	lower coordinate	-20 mm	-1.7 mm	-37 mm
$i1$	Bias current	2.7 A	4 A	2.5 A
$i2$	control current	1.7 A	2 A	1 A

with nominal variables listed in Table 2.

As the EM force value tends to be higher when the armature is near to upper pole, the total air

gap from bottom is limited to 1 mm instead of 1.5 mm. The ARSM optimizer of Optiy was used to carry out optimization.

After 16 iterations, the error in objective function comes to as low as 41 from 700. Figure 10 shows the Objective function finds a fast minimization in ARSM. The Figure 11 shows the closeness of target and archived Force-air gap curve.

TABLE 3					
OPTIMIZED VARIABLE AFTER 16 ITERATION OF ARSM (NO. OF ITERATIONS - 16)					
Name	y0r	y0u	i1 (A)	i2 (A)	objective
Values	-20.4	-45.7	2.55	1.92	41.25

The best solution (Table 3) was set for the variable and used as the starting point for subsequent Evolution strategy. In second and last step of optimization process, a tougher target is set as described following to target for a more flat EM force-air gap behavior.

$$f(x)_{target} = K_{x(target)} * x + f_l$$

where  $K_{x(target)} = 500 \frac{N}{mm}$  and  $f_l = 500 N$ ,

So a target of  $K_{x(target)} = 500 N/mm$

$f_l =$  Force at lower most position = 500 N.

The optimizer was set for 1500 steps and found to reach a Utopia point i.e. with the given design setting and constraint, the design vector cannot be improved upon further. So, the optimized variable those arrived at are given in Table 4.

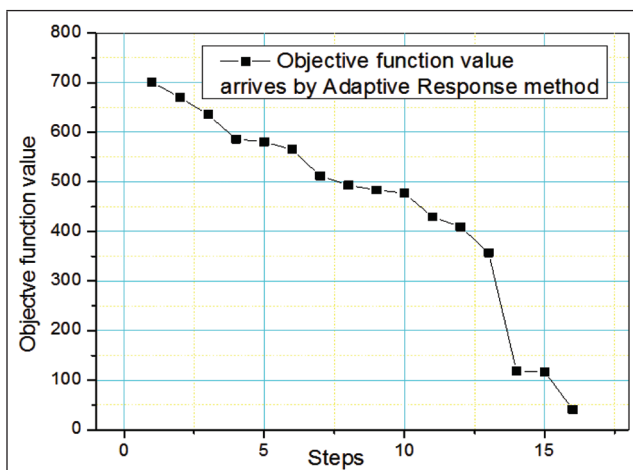

FIG. 10 OBJECTIVE FUNCTION MINIMIZATION

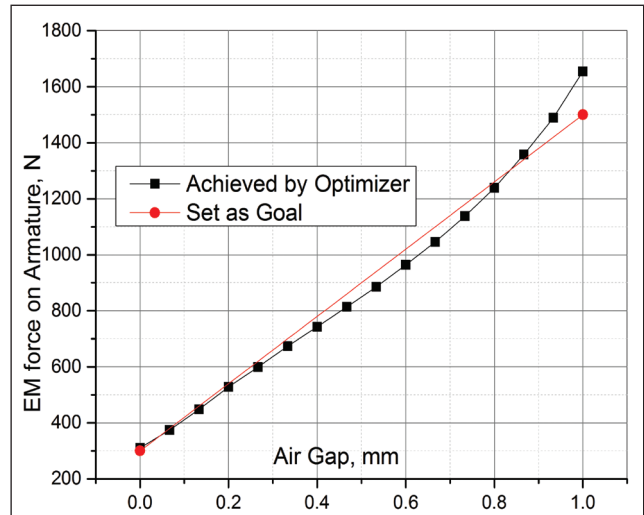

FIG. 11 COMPARISON OF TARGET SET AND ACHIEVED

Force-position behavior Optiy was used to carry out the optimization with its evolution strategy feature. after 1500 iterations. The objective function value of 97 is reasonable for this tougher target. Four parents and 20 children were set for optimizer. Elitist approach (Best of parents and children take part in successive regeneration) was chosen.

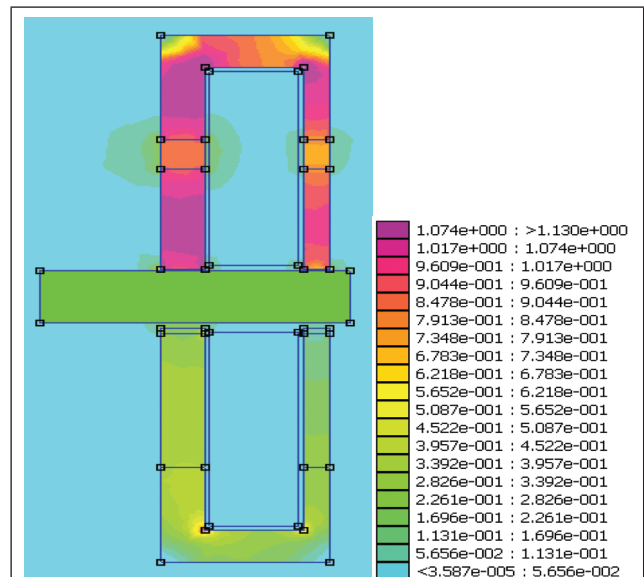

FIG. 12 FLUX DENSITY IN OPTIMIZED ACTUATOR WITH THE HELP OF EVOLUTIONARY ALGORITHM

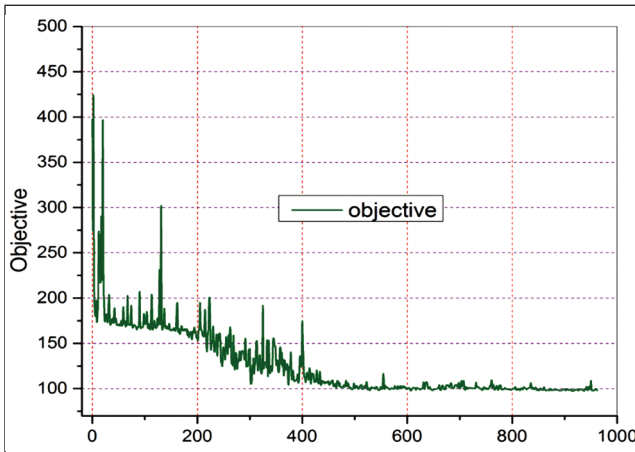

FIG. 13 OBJECTIVE FUNCTION MINIMIZATION WITH THE HELP OF EVOLUTIONARY STRATEGY OF OPTIMIZER

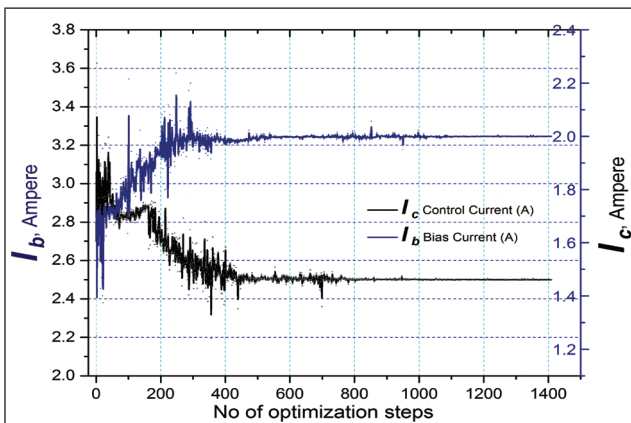

FIG. 14 CONTROL CURRENT AND BIAS CURRENT VALUES WITH ITERATIONS OF EVOLUTION STRATEGY

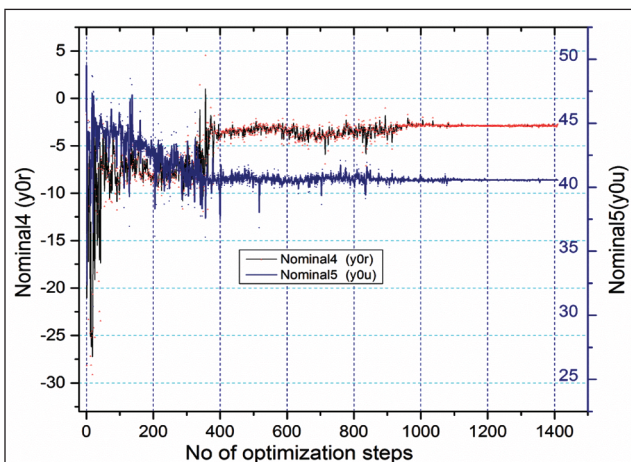

FIG. 15 LOWER AND UPPER CO-ORDINATES THAT SEPARATES MUMETAL AND CRGO STEEL

TABLE 4					
OPTIMIZED VARIABLE AFTER 496 ITERATION OF ARSM					
Name	y0r	y0u	i1 (A)	i2 (A)	objective
Values	-2.71	-45.7	2.50	1.99	97.1

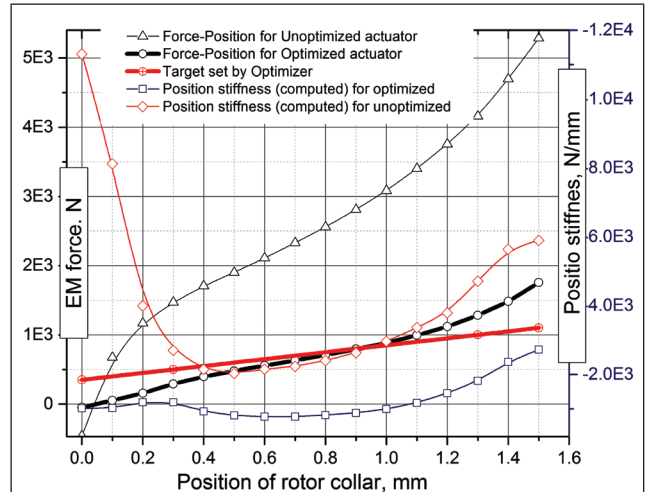

FIG. 16 COMPARISON OF OPTIMIZED AND UN OPTIMIZED ACTUATOR

During optimization by Evolution strategy, the air gap is extended in both direction (up and down) by 0.25 mm, resulting in total gap of 1.5 mm.

It can be seen in Figure 12 that the value of maximum flux density limited to 1.07 Tesla (in the case of armature in upper most position) due to early saturation of Mumetal (0.63 Tesla).

The Optimized values are as shown in Table IV. Figure 13 shows that after 900 steps, there is not much change in objective function. Figure 14 and 15 shows the values of nominal variables that vary with optimization steps. They are almost constant after 900 steps. Figure 16 shows that there is a difference between target set (tougher) and archived one. However, with tougher target of slope 500 compared to the one achieved in first attempt (slope 1200), open loop position stiffness is more flat rendering easier control for rotor position over the range of its position. the figure also shows the variation computed position stiffness across the gap of 1.5 mm. The un-optimized one varies from 11284 to 2025 N/mm where as the optimized one is less variant (770 N/



mm to 2721 N/mm). the stiffness in lower portion as computed to be almost constant.

### 7.0 EVALUATION OF OPTIMIZED AMB AND DISCUSSION

Through goal driven optimization followed by probabilistic analysis shows, it is possible to realize a magnetic bearing for large gap operation. Pre-fabrication 2D model is presented in Figure 16.

Subsequently, the variation of coil inductances were evaluated with air gap and control currents, with normal operating control current is taken as 2.5A. The control current has to be varied continuously by a linear amplifier when analog PID is implemented or has to be varied as per Pulse width Modulated supply decided when a digital controller is used. The actuator coil inductance limits the current slew rate, thereby, imposing a limited control action. It can be seen that the upper coil inductance is less than half as compared to un-optimized actuator (Figure 17). This improves  $l \, di/dt$  problem, thereby mitigating the problem faced by power supply to coil. Figure 17 also shows the upper coil inductance ratios with air gap and control current. With optimized geometry freezed, the open loop position stiffness and current stiffness behavior is re-assessed. These values are computed from EM force-air gap & EM force-Control current computations as carried out by FEM. Figure 18 and 19 shows the EM force-rotor position and position stiffness behaviour with rotor at top position and bottom position respectively. Figure 20 and 21 shows the current stiffness with control current for rotor at top and bottom position respectively. Two cases are considered: *case -1*: rotor at upper end, *case -2*: rotor at lower end.

*Case-1* As per Figure 20, when the actuator is in upper side, the control current tries to reduce. However, in this region, the current stiffness increases with lower control current, as the actuator gets recovered from magnetic saturation with lower control current. This, in addition with higher position stiffness makes the rotating bearing unstable. In case of optimized one, the

coil inductance reduces to less than half of un-optimized one, thus, current variation is much easier. In addition, the current stiffness is lower and reduces when the rotor nears the actuator, thereby, avoiding being stumbled against the pole face.

*Case-2* As per Figure 21 when the actuator is in lower end, the position stiffness is exceedingly. The upper coil carries  $I_b+I_c$  and lower coil carries  $I_b- I_c$ . As the control current is higher when the rotor moves towards bottom, the lower coil carries almost negligible current. In case of optimized one, the operating control current is 1.2 A when the rotor is at centre and it has to change to 2.25 A when the rotor is at bottom. Towards the bottom end, as the control current increases, the current stiffness also increases, thereby, stabilizing the rotor at lower end. As can be seen from the computed results and subsequent tuned PID values, the reference tracking is more robust at lower end of magnetic bearing, which otherwise will be unstable for conventional magnetic bearing. The control effort at bottom end position is less than at top position).In fact, the required P and I gains reduces, thereby, avoiding magnetic saturation problem. An comparative P, I and D values are given in Table 5 shows that more integral effort is required in case of un-optimized one.

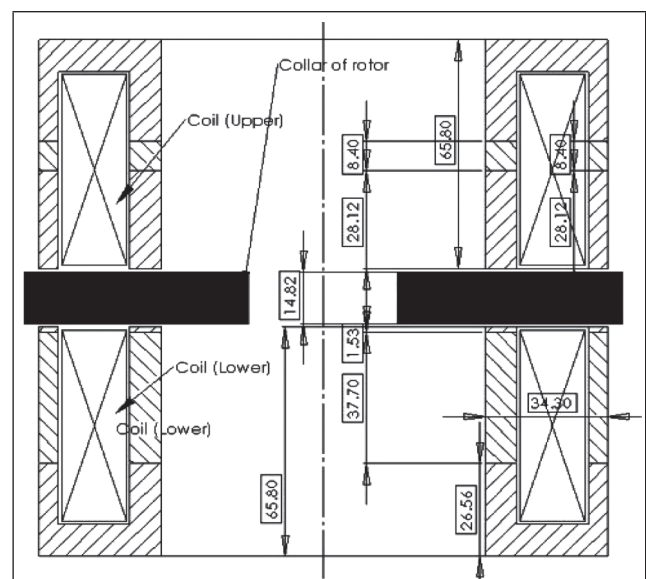

FIG. 17 OPTIMIZED CROSS-SECTIONAL VIEW OF AXIAL AMB ACTUATOR WITH SALIENT DIMENSIONS

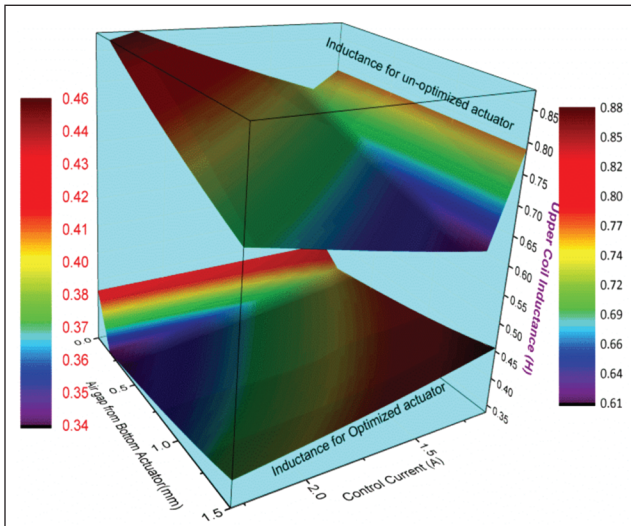

FIG. 18 UPPER COIL INDUCTANCE WITH CONTROL CURRENT AND AIR GAP

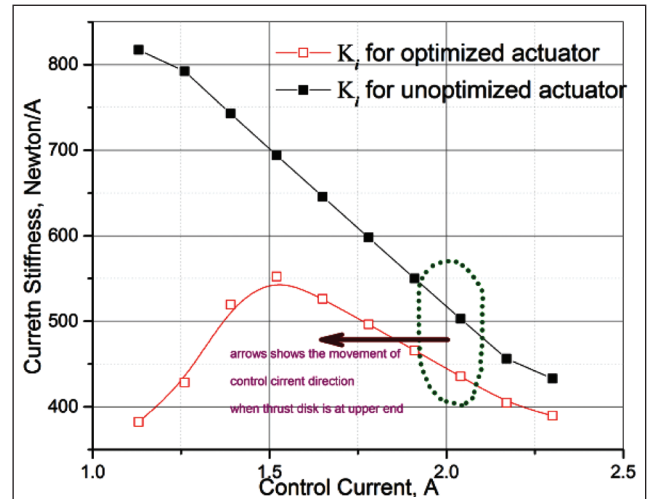

FIG. 21 CURRENT STIFFNESS WITH CONTROL CURRENT WITH ROTOR IN UPPER END OF ACTUATOR

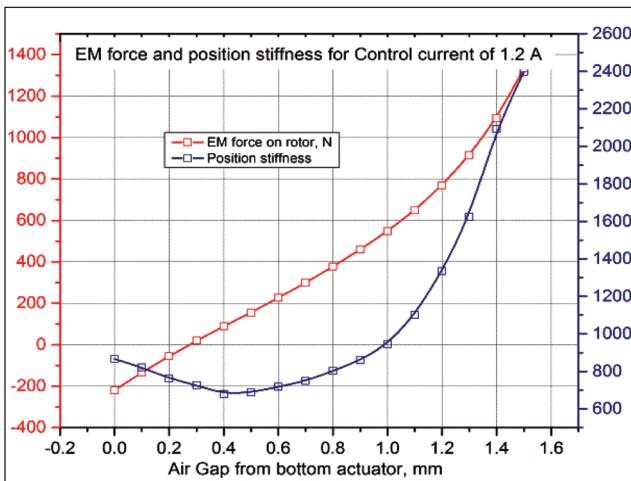

FIG. 19 EM FORCE-ROTOR POSITION AND POSITION STIFFNESS CONTROL CURRENT OF 1.2 A (REQUIRED FOR ROTOR IN CENTRE POSITION)

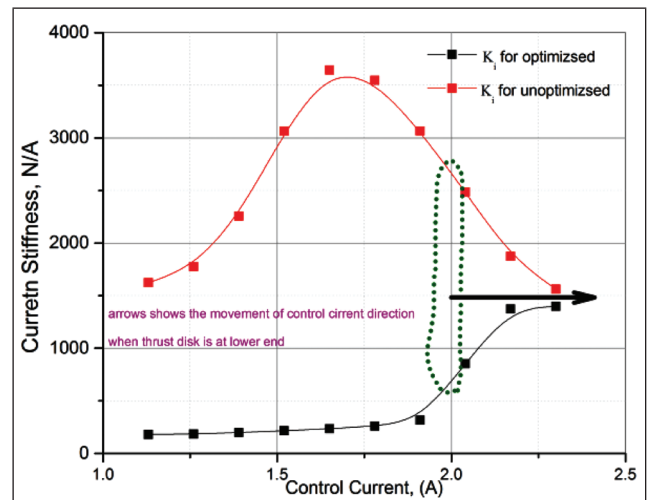

FIG. 22 CURRENT STIFFNESS WITH CONTROL CURRENT WITH ROTOR BOTTOM END OF ACTUATOR

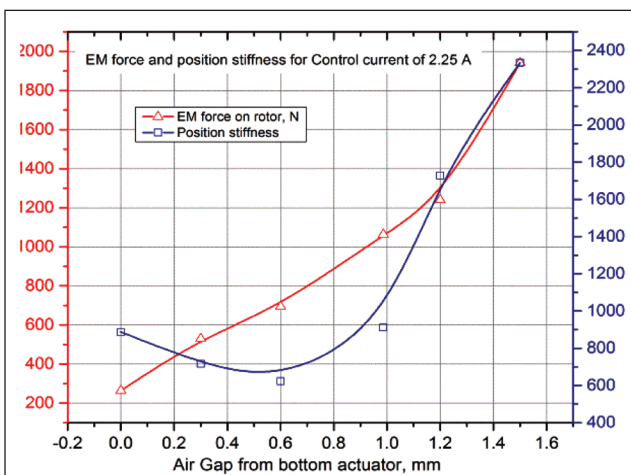

FIG. 20 EM FORCE-ROTOR POSITION AND POSITION STIFFNESS CONTROL CURRENT OF 2.25 A (REQUIRED WHEN ROTOR AT BOTTOM END)

TABLE 5

PID VALUES FOR OPTIMIZED AND UN-OPTIMIZED ACTUATOR					
Tuned PID values for Controller with Rotor at Top and bottom Position for an optimized actuator					
	(K <sub>x</sub> ) N/ mm	(K <sub>i</sub> ) N/A	P (A/ mm)	I (A/ mms)	D (As/ mm)
Top position	5896	1310	15.806	24.06	0.94
bottom position	11284	5310	11.706	28.78	0.39
Tuned PID values for Controller with Rotor at Top and bottom Position for optimized actuator					
Top position	2721	250	16.29	11.0045	2.1908
bottom position	1009	900	4.731	3.266	0.622

## 8.0 CONCLUSION

The following are the general conclusions that can be drawn as extension from the present study on development of Large gap Axial Magnetic Bearing in particular and any active magnetic bearing in general.

(i) Temperature variations along the shaft of Active Magnetic bearing for centrifugal sodium pump necessitates for more operating air gap between rotor and magnetic actuator placed on both sides of it. As the high open loop position stiffness requires more control effort, this may result in non-reliability of a practical controller to mitigate the effect of high value of pole in right side. A novel design was proposed to meet these design requirement. A goal driven optimization was carried out using ARSM and evolution strategy methods. With the help of two-core material concept, A less variant position stiffness across 1500 microns air gap was arrived at after getting optimized design variables constituting geometry and excitation current parameters using above comprehensive optimization method. Now, this investigations opens up a new way to attain position stiffness in AMB system which is less sensitive to positional variation of rotor in air gap.

(ii) The deterministic optimized model realized from optimization was subjected to stochastic analysis and variance based sensitivities of position stiffness with respect to critical parameters were obtained. This helps in specifying tolerance value during fabrication of AMB. As, this investigation is first of its kind with respect to Active Magnetic bearing, there is a great scope of refinement of design towards a more robust operation of large air gap magnetic bearing

## REFERENCE

- [1] Zhu, K. Y., Y. Xiao, and Acharya U. Rajendra. "Optimal control of the magnetic bearings for a flywheel energy storage system." *Mechatronics* 19.8 (2009): 1221-1235.
- [2] Kim, Ha-Yong, and Chong-Won Lee. "Design and control of active magnetic bearing system with Lorentz force-type axial actuator." *Mechatronics* 16.1 (2006): 13-20.
- [3] Kimman, M. H., H. H. Langen, and R. H. Munnig Schmidt. "A miniature milling spindle with active magnetic bearings." *Mechatronics* 20.2 (2010): 224-235.
- [4] Aenis, M., E. Knopf, and R. Nordmann. "Active magnetic bearings for the identification and fault diagnosis in turbomachinery." *Mechatronics* 12.8 (2002): 1011-1021.
- [5] J. W. Beams, J. L. Young, and J. W. Moore. "The production of high centrifugal fields." *Journal of Applied Physics*, 17:886-890, 1946.
- [6] Rao, Jagu S., and R. Tiwari. "Design optimization of double-acting hybrid magnetic thrust bearings with control integration using multi-objective evolutionary algorithms." *Mechatronics* 19.6 (2009): 945-964.
- [7] David Meeker, *Optimal Solutions to the Inverse Problem in Quadratic Magnetic Actuator*, Research Thesis, University of Virginia, May 1996
- [8] Cheng, Shanbao, et al. "Optimization of a hybrid magnetic bearing for a magnetically levitated blood pump via 3-D FEA." *Mechatronics* 21.7 (2011): 1163-1169.
- [9] Gruber, W., et al. "Wide air gap and large-scale bearingless segment motor with six stator elements." *Magnetics, IEEE Transactions on* 46.6 (2010): 2438-2441
- [10] Reichert, Thomas, Thomas Nussbaumer, and Johann W. Kolar. "Bearingless 300-W PMSM for bioreactor mixing." *Industrial Electronics, IEEE Transactions on* 59.3 (2012): 1376-1388.
- [11] Nguyen, TrongDuy, et al. "A novel axial flux permanent-magnet machine for flywheel energy storage system: design and analysis." *Industrial Electronics, IEEE Transactions on* 58.9 (2011): 3784-3794.

- [12] Bangcheng, Han, et al. "Integral design and analysis of passive magnetic bearing and active radial magnetic bearing for agile satellite application." *Magnetics, IEEE Transactions on* 48.6 (2012): 1959-1966.
- [13] Lim, Sunghoon, and Seungjae Min. "Design optimization of permanent magnet actuator using multi-phase level-set model." *Magnetics, IEEE Transactions on* 48.4 (2012): 1641-1644.
- [14] Wang, Laili, et al. "A horizontal-winding multi-permeability distributed air-gap inductor." *Applied Power Electronics Conference and Exposition (APEC), 2012 Twenty-Seventh Annual IEEE. IEEE, 2012.*
- [15] Saling, Kristin Graham, and K. Preston White. "Integrating probabilistic design and rare event simulation into the requirements engineering process for high-reliability systems." *International Transactions in Operational Research* 20.4 (2013): 515-531.
- [16] Duan, Yao, and Dan M. Ionel. "A review of recent developments in electrical machine design optimization methods with a permanent magnet synchronous motor benchmark study." *Energy Conversion Congress and Exposition (ECCE), 2011 IEEE. IEEE, 2011.*
- [17] Anyong Qing and ChingKwang Lee, "Differential Evolution in Electromagnetics, Page 60"
- [18] Wang, G. Gary, Zuomin Dong, and Peter Aitchison. "Adaptive response surface method--a global optimization scheme for approximation-based design problems." *Engineering Optimization* 33.6 (2001): 707-734.
- [19] Kunakote, Tawatchai, and SujinBureerat. "Multi-objective topology optimization using evolutionary algorithms." *Engineering Optimization* 43.5 (2011): 541-557.
- [20] Beyer, Hans-Georg, and Hans-Paul Schwefel. "Evolution strategies--A comprehensive introduction." *Natural computing* 1.1 (2002): 3-52.
- [21] eK Germany, OptiY. "Design for Reliability and Robustness through probabilistic Methods in COMSOL Multiphysics with OptiY."
- [22] Maslen, Eric H., and Gerhard Schweitzer, eds. *Magnetic Bearings: Theory, Design, and Application to Rotating Machinery.* Springer, 2009.
- [23] Akira Chiba, Tadashi Fukao, et al. Page 49, *Magnetic Bearing and Bearing less Drives,* Elsevier, 2005
- [24] Rechenberg, Ingo. "Evolutionsstrategie-Optimierung technischer Systeme nach Prinzipien der biologischen Evolution." (1973).
- [25] Beyer, Hans-Georg, and Hans-Paul Schwefel. "Evolution strategies--A comprehensive introduction." *Natural computing* 1.1 (2002): 3-52.