

Design of AC-DC converter with reduced harmonics and output ripples using active power factor correction technique

Vani Vijay*, Giridhar Kini P**, Viswanatha C*** and Jothi Basu S****

AC-DC converters are very commonly used in many power electronics applications including controllable sources and machine drives. Rectifier circuit results in harmonic distortions in AC side and requires large capacitive filter for reducing DC ripples on the output side. Use of active power factor technique can be utilized for solving this issue resulting in better performance of the converter. It basically consists of boost converter with high frequency switching following the rectifier controlled using a suitable microcontroller. This paper presents the detailed design and operation of Active power factor corrected rectifier which operates with reduced THD and improved power factor there by reducing losses in power flow and utility. Simulation of the designed converter and comparison with conventional topology is also discussed.

Keywords: Rectifier; active power factor correction, capacitive filtering

1.0 INTRODUCTION

Power electronic converters are inevitable in modern power system and power utility areas. AC-DC converters are commonly used in many applications which includes power conditioning and control. A constant DC link voltage is necessary for the efficient operation of all controllable AC sources, multi level inverters, variable frequency drives, and motor control based on field oriented control, switched reluctance, constant flux etc. In most of the cases, conventional AC-DC rectifiers are used with large capacitive filtering. Use of active power factor correction circuit results in reduced harmonic distortion and output DC with less ripple content [1-4].

An overview about the conventional converter is given in section II. The design and operation of a high performance AC-DC converter is described

in section III. Section IV gives the simulation results of the circuit designed in section III along with comparison of conventional circuit and rectifier with Active PF correction circuit.

2.0 CONVENTIONAL AC-DC CONVERTER

Figure 1 shows the circuit diagram of conventional rectifier with capacitive filter without active power factor correction. This is a primitive configuration. The output of the full bridge rectifier is pulsating and is filtered using output capacitor. Figure 2 gives the typical waveforms of input AC, Full wave rectified AC and DC output after capacitive filtering [5-6].

These converters cause network losses and increase the harmonic content and high EMI emission which demands better designed filters.

*Energy Efficiency and Renewable Energy Division, Central Power Research Institute, Bangalore - 560080. E-mail : vani.cpri@gmail.com;

**E&E Department, Manipal Institute of Technology, Manipal - 576104

***Diagnostics Cables and capacitors Division, Central Power Research Institute, Bangalore - 560080

****Energy Efficiency and Renewable Energy Division, Central Power Research Institute, Bangalore - 560080

This is because the current drawn from the mains will be pulsating and discontinuous. The amount of ripples in output voltage can be seen in Figure 2.

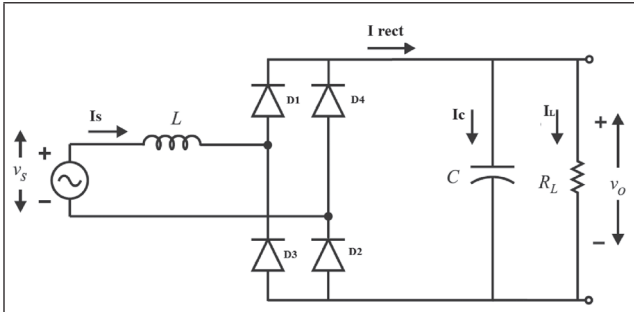

FIG. 1 AC-DC CONVERTER WITH CAPACITOR FILTERING

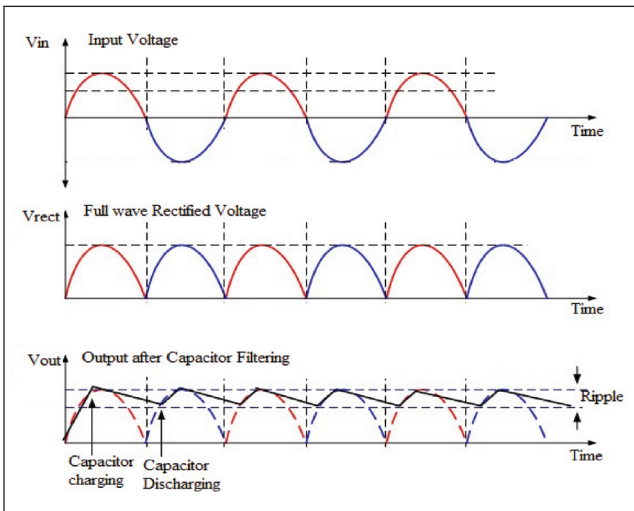

FIG. 2 AC-DC CONVERTER OUTPUT WAVEFORMS

3.0 ACTIVE POWER FACTOR CORRECTION

3.1 Working Principle

The basic diagram of an active PF Correction circuit is shown in Figure 3. The input AC is full wave rectified followed by the inductor. The rectified wave is scaled down to suitable level and is used as reference for obtaining the duty cycle for the switching MOSFET. The current waveform is made to closely follow the input voltage waveform using a suitable microcontroller. Therefore the microcontroller should have the instantaneous values of input AC Voltage, output DC voltage and inductor current. Suitable sensors, voltage dividers and Analog to Digital converters should

be provided. The duty cycle is obtained by using PI controller for current and voltage regulation as shown in the Figure [6-8].

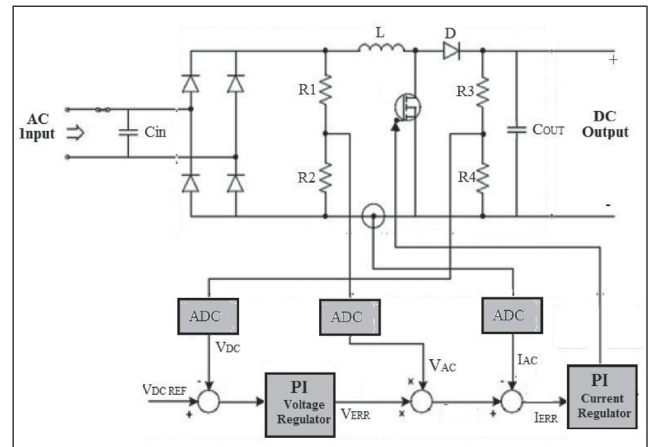

FIG. 3 ACTIVE POWER FACTOR CORRECTION OPERATION

3.2 Design of PF corrected Rectifier

The important parameters to be designed include input capacitor, Inductor, Output capacitor and power ratings of power diode and the MOSFET. The initial parameter ratings for a 1 kW converter with power factor correction are shown in Table 1.

TABLE 1 CONVERTER RATINGS		
Sl. No.	Parameter	Value
1.	Input AC Voltage (V_{in})	200-260V
2.	Output DC Voltage (V_{out})	400 V
3.	Rated Power (P)	1000W
4.	Input PF	>0.99
5.	AC Voltage Frequency (f)	50Hz
6.	Switching Frequency (f_s)	50 kHz

Input current $I_{in\ rms}$ is given by equation (1)

$$I_{in\ rms} = \frac{P_{Out}}{\eta V_{in(min)} \cdot pf} \quad \dots(1)$$

Where η is the efficiency of converter

$$I_{in\ rms} = \frac{1000}{0.97 \times 200 \times 0.99} = 5.206\text{ A}$$

$$I_{in(Peak)} = \sqrt{2} \times 5.206 = 7.361A \quad \dots(2)$$

$$I_{in(Average)} = \frac{2 \times 7.361 \times \sqrt{2}}{\pi} = 6.629 A \quad \dots(3)$$

Input Capacitor:

Input Capacitor is to be designed based on the input voltage and current ripple factors which are assumed to be 15% and 5% respectively.

$$C_{input} = \frac{I_{ripple}}{8f_s \cdot V_{in_ripple} A} \quad \dots(4)$$

$$V_{in_ripple} = 0.05 \times V_{in(Peak)max} = 18.382V \quad \dots(5)$$

$$C_{input} = \frac{I_{ripple}}{8f_s \cdot V_{in_ripple}} \quad \dots(6)$$

$$C_{input} = \frac{1.104}{8 \times 50 \times 10^3 \times 18.382} = 0.15 \mu F \quad \dots(7)$$

Inductance Calculation:

$$I_{L(Peak)} = I_{in} + \frac{I_{ripple}}{2} = 5.758 A \quad \dots(8)$$

Where I_L indicates inductor current.

$$I_{L(Average)} = \frac{2 \times 5.758 \times \sqrt{2}}{\pi} = 5.185 A \quad \dots(9)$$

$$L_{min} = \frac{(V_{out} - V_{in_Peak(min)}) \cdot V_{in_Peak(min)}}{V_{out} \cdot f_s \cdot I_{in_ripple}} \quad \dots(10)$$

$$L_{min} = \frac{(400 - 282.8) \cdot 282.8}{400 \times 50 \times 1000 \times 1.104} = 1.5 \text{ mH}$$

Output Capacitor:

$$C_{Out} = \frac{I_{out(max)}}{2\pi f_s \cdot V_{out_ripple}} \quad \dots(11)$$

$$C_{Out} = \frac{1000 / 400}{2\pi \times 50 \times 1000 \times 400 \times 0.05} = 0.39 \mu F$$

The complete implementation will include input filter, Protection circuit for over current over

voltage, under voltage etc. The complete block diagram of the proposed system is shown in Figure 4 [9-10].

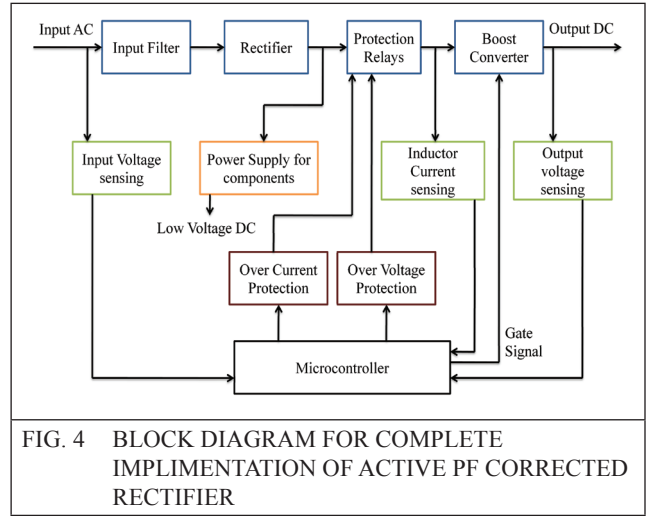

FIG. 4 BLOCK DIAGRAM FOR COMPLETE IMPLIMENTATION OF ACTIVE PF CORRECTED RECTIFIER

4.0 SIMULATION RESULTS

The circuit parameters designed for Active Power Factor Corrected circuit in section 3.2. is simulated using Matlab Simulink platform along with a conventional AC-DC converter for comparison [11-12]. The overall simulation diagram is shown in Figure 5. The designed parameter values are found to provide expected results from the circuit. The input and output waveforms of the simulated model is shown in Figure 6.

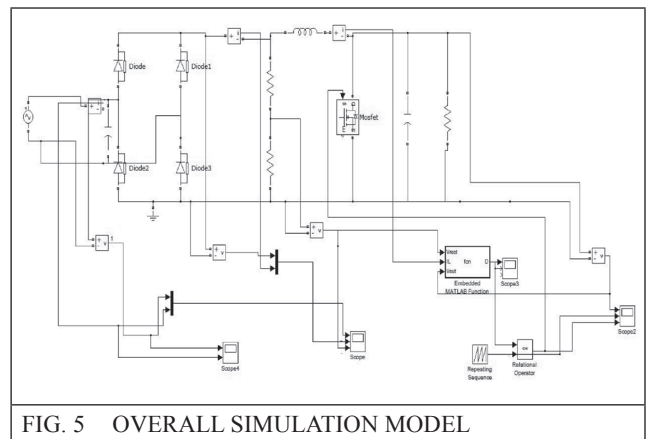

FIG. 5 OVERALL SIMULATION MODEL

The Input THD and output ripple factor for rectifier with capacitive filter and Rectifier with Active Power Factor Correction is compared at various loading steps from 10% to 100%. The bar chart of comparison is shown in Figure 7. Green indicates rectifier with capacitive filter

and blue indicates Rectifier with Active Power Factor Correction. Active PF correction is found to improve the performance of the system by reducing THD and Voltage ripples

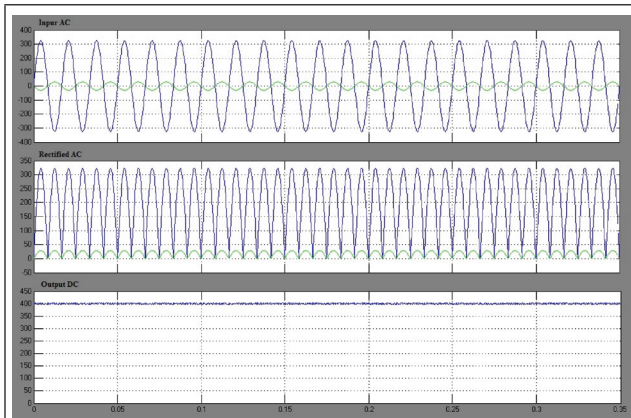

FIG. 6 ACTIVE PF CORRECTED RECTIFIER WAVEFORMS

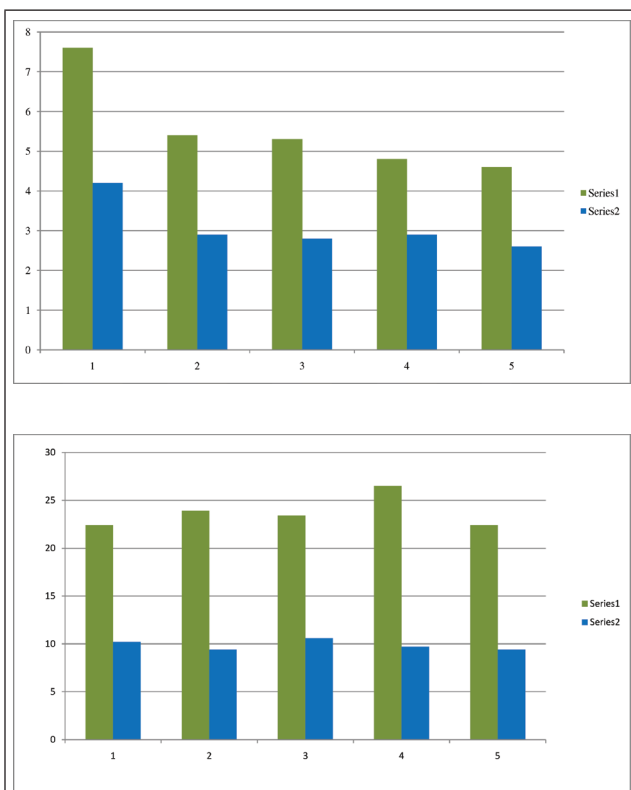

FIG. 7 COMPARISON OF THD AND DC RIPPLES

5.0 CONCLUSIONS

Active Power Factor Correction is a well known technique for improving the power factor and reducing the Total Harmonic Distortion of power electronic converters. Design and simulation of a 1kW model is presented. Use of APFC for

rectifiers gives better voltage regulation and reduced THD levels, consequently reduced the losses in power flow. Improvement in power factor is also obtained which reduces energy cost and improves the capacity to serve power.

ACKNOWLEDGEMENT

The work is supported by Central Power Research Institute (CPRI), Bangalore, India. The studies were carried out in the solar PV and inverter testing laboratory of Energy Efficiency and Renewable Energy Division, CPRI Bangalore and the works are done with the guidance of the experts from the Organization.

REFERENCES

- [1] Schlecht MF; Miwa, Brett A, "Active Power Factor Correction for Switching Power Supplies," IEEE Transactions on Power Electronics, vol. PE-2, no. 4, pp. 273-281, Oct. 1987
- [2] Jovanovic, M M; Yungtaek Jang, "State-of-the-art, single-phase, active power-factor-correction techniques for high-power applications - an overview," IEEE Transactions on Industrial Electronics, , vol. 52, no. 3, pp.701-708, June 2005
- [3] Yong-Won Cho; Jung-Min Kwon; Bong-Hwan Kwon, "Single Power-Conversion AC--DC Converter With High Power Factor and High Efficiency," Power Electronics, IEEE Transactions on, vol. 29, no. 9, pp. 4797-4806, Sept. 2014
- [4] Meral M E, "Using active power factor correction (PFC) boost rectifiers for an improved topology of static series compensators with no energy storage," IET Power Electronics, vol.5, no.8, pp.1438-1445, September 2012
- [5] Ned Mohan, Tore M Undeland, William P Robbins, "Power Electronics : Converters, Applications, and Design", Wiley, 2002
- [6] Muhammed H Rashid, "Power Electronics: Circuits, Devices and Applications", Pearson Education India, 2003.

- [7] Prasad A R; Ziogas, P D.; Manias S, "An active power factor correction technique for three-phase diode rectifiers," IEEE Transactions on Power Electronics, Vol.6, No.1, pp.83-92, Jan 1991
- [8] Wolfle W H; Hurley W G, "Quasi-active power factor correction with a variable inductive filter: theory, design and practice," IEEE Transactions on Power Electronics, , Vol.18, No.1, pp.248-255, Jan 2003
- [9] Blundell R; Kupka L; Spiteri S, "AC-DC converter with unity power factor and minimum harmonic content of line current: design considerations," IEE Proceedings - Electric Power Applications, Vol.145, No.6, pp. 553-558, Nov 1998
- [10] ST Microelectronics, UM0877, "1.4 kW digital power factor corrector based on the STM32F103ZE", pp 1-62, April 2010.
- [11] Houenagnon MA ; Cheriti A, "Comparative simulation study of two three-phase active single-switch topologies for power factor correction," Canadian Conference on Electrical and Computer Engineering, 1996. Vol.2, No., pp.984-,987 Vol. 2, 26-29 May 1996
- [12] WangSu;HeMing, "Researchandsimulation of active power factor correction," , 2011 International Conference on Consumer Electronics, Communications and Networks (CECNet), Vol., No., pp.5156-5158, 16-18 April 2011

