

# Power System Reliability in Distributed Generation Environment: A Review

Gousia Sultana\* and B. K. Keshavan

EEE Department, VTU, PES Research Centre, Bengaluru – 560085, Karnataka, India;  
gousi0212@gmail.com

## Abstract

This paper gives the review of the research on power system reliability assessment with Distributed Generation (DG). The primary importance of a power system is to provide the economical, reliable electrical energy supply to the customers without any interruption. The evaluation and assessment of the reliability of power system is the most significant aspect in designing and planning the distribution systems so that the distributed systems should supply electrical energy in economic manner without any interruption of customer loads.

**Keywords:** Adequacy, Distributed Generation, DG, Power System Reliability

## 1. Introduction on Power System Reliability

An electric power system supplies both the large and the small customers, with electrical energy which is not only economical but also reliable. The ability to provide adequate supply of electrical energy over the period of time desired under the working conditions is the reliability. The concept of power system reliability can also be defined broadly as the overall ability of the system to fulfill the needs of the customer load requirements in an economical and reliable way. In the simpler terms, power system reliability is mentioned using the two basic features; they are system adequacies and the system security. System adequacy is the presence of sufficient facilities inside the system to fulfill customer load demands. These include facilities for electrical power generation, facilities for transmission of the power and facilities for distribution which is required to transfer the electrical energy generated from source to the desired load points. Thus the Adequacy represents the static condition of the system. If the system is subjected to any disturbances/perturbations, then the response of the system towards

those perturbations is the security of the system. These disturbances may also include various local and widely spread disturbances associated with the system and loss of energy in major part of the generation/transmission<sup>1</sup>.

Electric power system can be divided into three levels of hierarchy for the purpose of reliability evaluation<sup>2</sup>.

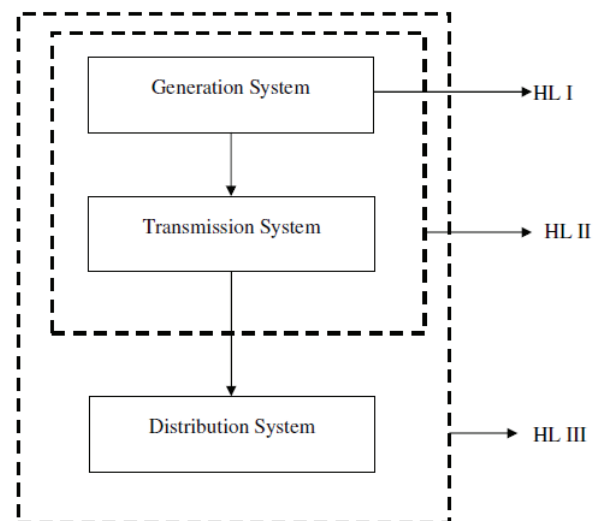

Figure 1. Three hierarchy levels of power system<sup>2</sup>.

\*Author for correspondence

HLI are concerned with the evaluation of the reliability factors of generation system. The main indices analysed are as given below:

- Loss of Load Expectation (LOLE).
- Loss of Energy Expectation (LOEE).
- Failure Frequency.
- Failure Duration.

In HLI study only the power generating systems are considered and the impact on reliability of Transmission and Distribution (T&D) systems are neglected.

In Hierarchy level II (HLII), both the generation and the transmission systems are taken into account. This study is used to evaluate the reliability of a present operating system (in place) or a proposed system (to be installed). From these studies the output related to each bus and the output for overall system can be obtained. The main reliability indices being considered are the frequency of failure and the duration of failure.

Hierarchy level III (HLIII) refers to the complete power system including the generation system, transmission system and also the distribution system. Due to the huge complexity in such systems, evaluation of the complete system is not done. The load point indices from HLII phase can be used as the input in evaluating the reliability distribution system in HLIII. SAIFI, SAIDI and CAIDI are considered as the main indices in evaluating the reliability.

## 2. Distributed Generation Overview

The other names of Distributed Generation (DG) are dispersed generation, decentralized generation or embedded generation. Distributed generation can be defined in simple words, as any electrical energy source of limited size or capacity connected directly to the distribution system of a power system network. Distributed Generation (DG) is also referred to as “embedded generation” or “dispersed generation”, which relates to small scale power generation which is integrated properly within distribution systems. Generally DG is installed close to the load point (point of use) and it can be powered by number of power sources, from both conventional sources and non-conventional sources, like solar energy source (photovoltaic cells), wind turbine generators, fuel cells, micro turbines, combustion gas turbines, etc<sup>3</sup>.

In all sectors across the Globe, consumption of electricity is increasing rapidly. In this modern era, the demand of electrical energy is growing rapidly; the best possible way to satisfy the rapid growth in electrical energy demand is to promote the numerous deployment of Distributed Generation (DG) as it can effectively be operated in parallel with the main grid<sup>4</sup>.

The few important advantages of the installation of DG's near the load points are loss reduction in the system energy, voltage profile enhancement and reliability improvement. DG also ensures the reduction in operational costs and is quite easy to install in respect of investment cost and time of installation<sup>5</sup>.

Renewable energy based DG's play a prominent role in providing the sustainable, clean energy infrastructure without any environmental impacts. The main purpose of the Distribution systems is to supply power to consumers; but the introduction of DG in the system will change a distribution network's characteristics due to its bidirectional flow of power<sup>18</sup>. If there is large increase in the penetration level, then problem of the rising voltage may occur due to reverse flow of power<sup>6</sup>. Improper sizing and not appropriate placing of DG's may possibly result in larger amount of power loss in a system than compare to the system without the DG<sup>7</sup>. Therefore, the integration of a significantly large amount of Distributed Energy Resources (DER) with the distribution network may cause operational problems in the power distribution network. Thus, to obtain the stable, reliable, and efficient operation of a complete power distribution system, proper planning, sizing and siting of DG is highly important.

## 3. Impacts of DG on Reliability

Abdulaziz et al., applied a Monte Carlo simulation technique to obtain the reliability indices of RBTS Bus 2 system with inclusion of micro grid and also without micro grids. The impact of operation of micro grid in islanded mode on the distribution system network reliability is analyzed and presented and it is seen from the results that the installation of DGs in distribution system such as Photovoltaic (PV) and Wind Turbine (WT) has improves the reliability of the complete system. Component failures, variation in Wind Turbine (WT) and Photovoltaic (PV) output power and the repair time has been taken into account. The implementation of DGs near the consumer load improves the reliability of distribution network and it also offers a back up source to the load when there is no availability of

power from main source to the load. For the micro grids the improvement in reliability depends mainly on the proper selection of size of the DGs installed, location of DG's placed and also the distribution of DGs<sup>8</sup>.

Shouxiang et al., after analyzing the various features of distributed generation which operates as backup energy sources or behaves as the part of a micro grid system, evaluated the reliability indices of a RBTS bus-2 system for the distribution network. Author proposed a reliability evaluation technique which is based on traditional reliability evaluation method. Here the distributed generation of the network runs in two different modes separately is considered. There are three major operation modes of DGs depending on whether DG's are connected to bulk power system (Grid) and the different ways they are connected. These operation modes are one is DG used as back up source, second DG operating parallel with the main grid in order, and third DG installed to form a micro grid. From the results obtained it is observed that the average interruption time and fault duration time of the load points will be reduced when DGs are installed to operate as backup source to supply power, but the average rate of failure of the loads not altered. When the DGs used to run in parallel with the main utility grid, it is observed that load points indices and system indices is improved intern improving the total reliability of the complete system, and it is completely depend on determining the type of DG, proper placement, and power capacity of the DGs. When several types of DGs are used in forming a micro grid, then within the micro grid the average fault rate and average failure rate is reduced for the load points of the system. The proposed method is applied on RBTS system to depict the feasibility and accuracy of the system<sup>9</sup>.

M. Boonthienthong et al., used Tabu search-based method for the optimal siting of distributed generation in the distribution systems, the main aim is to increase the benefits of the reliability in terms of reducing the cost of customer interruption. From a reliability point of view, distributed generation is used to serve as a backup generation for those load points which would otherwise left disconnected due to faulty component until the repair of a faulted component had been completed and reconnected. The effectiveness of the method that is Tabu search is applied to evaluate the reliability of a distribution network of RBTS bus-2 system. It can be seen from the case study<sup>10</sup> that the use of distributed generation improves the reliability of the complete system and also reduces the customer interruption cost<sup>10</sup>.

S. Hakimi Gilani et al., determined optimal allocation of wind-based DG units by using GA method and also considered the uncertainty in the output power of wind turbines and load demand. Costs of annual power losses and the energy not supplied which is associated with the voltage constrain is considered as a multi-objective function. To exert multi step feature of the power generation and load demand, a Fuzzy c-means clustering has been used. Results show a significant reduction in energy losses as well as a remarkable enhancement in reliability issue as terms of energy not supplied; while, as a result of DG placement, regarding to the voltage constrain, voltage profile of busses has been improved about 3.3% including DG compare to without DG. Without DG the losses and energy not supplied obtained is 141.12 kw and 5827.6 kwh respectively, and it is observed after installing the DG losses and energy not supplied reduced to 89.75 kwh and 4862.5 kwh respectively. Proposed algorithm is capable to model other renewable DG such as Photovoltaic-DG units that suffer from uncertainly in their production<sup>11</sup>.

Mohammad Al-Muhaini and Gerald T. Heydt proposed a Markov model to determine the reliability of a future networked power distribution system for both conventional DG units and non-conventional DG units, during normal operating conditions. In forming the reliability model for DG unit for grid connected distribution system, the connection of the load to the utility grid is through the components and the feeders in the distribution network. In case if the power is not supplied to the load from the distribution system, the DG serves the purpose of supplying the power to the load in islanded operation. If the DG installed is a conventional source backup unit, then the DG is used to supply the power to the load only during emergency conditions. If the renewable source DG unit installed near the load then it is a base load unit, this DG unit can be used to operate continuously in parallel with the utility supply (grid supply), But in this case if any interruption takes place then the renewable resource has to be disconnected and again reconnect during interruptions. In order to obtain the reliability of the distribution system including DG, the Bus 4 of the RBTS is used. The failures occurred on the transformers and also the 11 kV and 33 kV feeders are considered for evaluating reliability. To simplify the simulation of the complexity of the future networked distribution system, all the interruption devices of the system, normally opened tie switches are taken as 100% reliable and these operate successfully whenever they are in need. From the results obtained it is concluded that

- The complete load demand cannot be supplied from the DG during the period of interruptions and this is because of the lower power generation in DG and also the power rating of the DG, especially if the DG unit is renewable source of energy.
- During the outages the DG which is working in an islanded mode operation improves the interruption duration but the frequency of interruption may increase in this condition. As the generating capacity of many renewable distributed energy sources is lower, experiencing inadequate energy generation probability increases.
- The proposed Encoded Markov Cut Set (EMCS) algorithm approach is used to evaluate the reliability; the study shows that the EMCS algorithm is effectively applicable for the reliability analysis of future distribution systems including both renewable and non-renewable DGs units<sup>12</sup>.

P. Pavani et al., applied the integer programming technique for the sizing and placement of DG. A search based reconfiguration algorithm is formulated in order to obtain the optimal switch configuration for the radial distribution network including DG. The methodology proposed is applied upon 33-node test distribution system and 69-node test distribution system as shown in Figure 2 and Figure 3 respectively. The distribution network is reconfigured with the distributed generation for improving the reliability of the system and minimizing the real power loss<sup>13</sup>.

It is observed from the results that after the optimal placement of DG, there is a reduction in the total losses by 76% and by considering the reconfiguration algorithm for both DG and tie-switches, 78% of losses got reduced and thus improving reliability. The total complex power generation (real and reactive power generation) is reduced to 49.7% which is fed from substation after the placement of DG and it further got reduced to 59.4% after the network reconfiguration. The system down time from 15.39 hours/year is decreased to 6.2209 hours/year. Thus it is

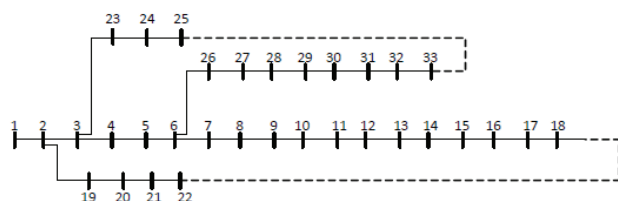

Figure 2. Modified 33-node distribution system<sup>13</sup>.

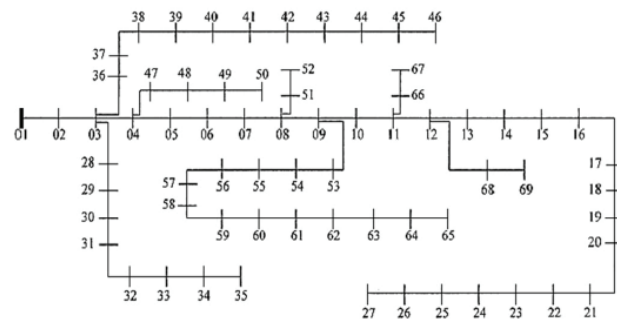

Figure 3. Distribution system of 66-node<sup>13</sup>.

concluded from the results obtained, that the reduction in the considerable amount of losses and also reliability improvement can be achieved by using the proposed method<sup>13</sup>.

Hong-shan et al., conducted a Case study by using time sequential Monte Carlo simulation method in which the impact of DGs on the reliability of distribution network of a small reliability test system which is based on the IEEE RBTS BUS6 is analyzed, where the test system is evaluated for three cases.

Case1: The system without DGs.

Case2: System with two DG'S those are Wind Turbine Generator (WTG) connected to the system at feeder 18 of the system and a Solar Cell Generator (SCG) to the system at feeder 30 as shown in Figure 4.

Case3: System with two DG'S with unlimited capacity.

From the results it is observed that the connection of DG near the load point reduces the failure rate of load point in particular location where DG is supplying power is accessed; the annual failure rate of load point in any other segments if get affected by the DG accessed is not obvious. The load point indices is then compared considering each case, it is shown that the connection of DG reduces the annual failure rate ( $\lambda$ ), annual unavailability, outage time( $r$ ) or repair time, and Energy not Supplied (ENS) of the load point in the segment where DG is accessed thus improving the reliability of the system; for the load point in any other segments, the failure rate may not reduce, but the annual unavailability, outage time, and energy not supplied is obviously reduced. Thus it is said that the connection of DG unit can improves the total reliability index of each system, greater the system reliability improvement with increase in the DG outputs<sup>14</sup>.

I. Waseem et al., conducted a case study of a residential distribution network of Virginia Tech Electric Services (VTES) in Blacksburg, reliability indices (SAIDI,



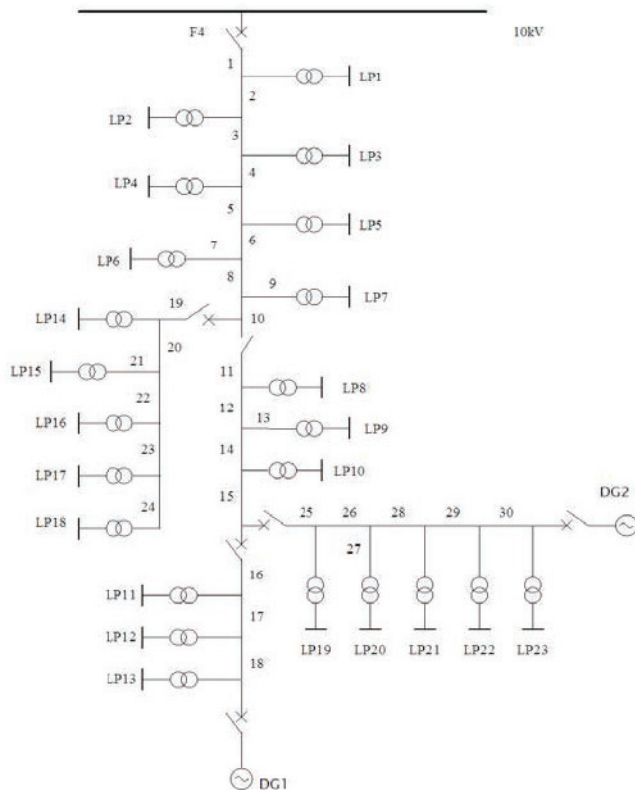

**Figure 4.** Connection diagram of distributed system<sup>14</sup>.

CAIDI and ENS) of an unbalanced three-phase radial distribution network is evaluated. 69 kV of electricity is purchased by VTES, and then 69 kV is converted to 12.47 kV at two distribution substations of Blacksburg and Lane substations. The reliability indices of the distribution system without DG with and without disconnects are obtained. Author showed that by adding disconnects on the main distribution line improves the reliability of the system significantly. SAIDI value increases from 1.3182 hrs/customer-yr to 0.71344 hrs/customer-yr, that is the improvement of 46%. CAIDI value boosts from 3.4309 hrs/customer-interruptions to 1.8602 hrs/customer-interruption, which is also the improvement of 46%. And ENS raises from 2303 kWh/yr to 1419 kWh/yr, which is improvement of 38%<sup>15</sup>.

P. Chiradeja performed the line loss reduction analysis by considering only single-concentrated load at the end of the transmission line. The DG is considered near the load which reduces the line losses. This factor is analyzed, for the different placement of the DG along with the feeder and for different capacities of DG. Two simple radial systems are assumed, first one is the system without considering the DG and second one is with DG. Both

the systems with and without DG have a concentrated single load at the end of the transmission line. If DG of the second radial system is used to supply the energy to the nearby load, then the line losses are reduced and it is because of the significant decrease in the current flow in some part of the network. This reduction in current flow happens due to the fact that DG installed is used to supply only some part of real and reactive power to the load. Thus, the total current flowing in the feeder from the source to DG location reduces, resulting in minimum electrical line loss. However, the higher rating DG's cannot always guarantee the lower line loss<sup>16</sup>.

S. Pahwa et al., has proposed an analytical method using Electrical Centrality which is obtained by forming the Bus Impedance Matrix in order to determine the size and location of DG. The method proposed has been tested on 12-bus, 33-bus, and 69-bus distribution systems. The results obtained for 12-bus distribution system shows the significant reduction in real and reactive power losses that 80% and 55.37% respectively and thus improves the Voltage profile. This method is tested for time-invariant load and this method has to be tested for time-varying renewable generation data and time-varying<sup>17</sup>.

## 4. Conclusion

This paper presents the concept of reliability and the impact of Distributed generation on the reliability of the distributed system. From the above study it is clearly observed that the inclusion of DG in the distributed system improves the reliability index of the complete system, it also reduces the transmission losses, improves the voltage, reduces the customer interruption cost, and improves power quality and overall energy efficiency of the system. There are several benefits of the DG in distribution network, in order to obtain stable, reliable and efficient power system the modeling of DG's, sitting and sizing of the DG is very critical aspect.

## 5. References

1. Roy B, Allan RN. Reliability assessment of large electric power systems. the Kluwer International Series in Engineering and Computer Science. Springer US; 1988.
2. Roy B, Allan RN. Reliability evaluation of power systems. ISBN 0-306-45259-6, Springer US; 1996.
3. Kaur N. Distributed generation models and its optimal placement in power distribution networks: A review.

- International Journal of Electrical and Electronics Engineers. 2015 Jan-Jun; 7(1). ISSN-2321-2055.
4. Dugan R, McDermott T. Distributed generation. IEEE Industry Applications Magazine. 2002; 8(2):19–25. <https://doi.org/10.1109/2943.985677>
  5. Chiradeja P, Ramakumar R. An approach to quantify the technical benefits of distributed generation. IEEE Transactions on Energy Conversion. 2004; 19(4):764–73. <https://doi.org/10.1109/TEC.2004.827704>
  6. Masters CL. Voltage rise: The big issue when connecting embedded generation to long 11 kV overhead lines. Power Engineering Journal. 2002; 16(1):5–12. <https://doi.org/10.1049/pe:20020101>
  7. Acharya N, Mahat P, Mithulananthan N. An analytical approach for DG allocation in primary distribution network. International Journal of Electrical Power and Energy Systems. 2006; 28(10):669–78. <https://doi.org/10.1016/j.ijepes.2006.02.013>
  8. Alkuhayli AA, Raghavan S, Chowdhury BH. Reliability evaluation of distribution systems containing renewable distributed generations. 2012 North American Power Symposium; 2012. 978-1-4673-2308-6/12/2012 IEEE. <https://doi.org/10.1109/NAPS.2012.6336324>
  9. Wang S, Li Z, Xu Q, Li Z. Reliability analysis of distributed system with DGs. 4<sup>th</sup> International Conference on Electric Utility Deregulation and Restructuring and Power Technologies (DRPT); 2011. DOI: 10.1109/DRPT.2011.5993855. <https://doi.org/10.1109/DRPT.2011.5993855>
  10. Boonthienthong M, Charoencheep NR, Auchariyamet S. Service restoration of distribution system with distributed generation for reliability worth. IEEE Conferences 47<sup>th</sup> International Universities Power Engineering Conference (UPEC); 2012. <https://doi.org/10.1109/UPEC.2012.6398620>
  11. Gilani SH, Afrakhte H, Ghadi MJ. Probabilistic method for optimal placement of wind-based distributed generation with considering reliability improvement and power loss reduction. IEEE Conference of the 4<sup>th</sup> Conference on Thermal Power Plants; 2012. P. 18–9. 2012.
  12. Al-Muhaini M, Heydt GT. Evaluating future power distribution system reliability including distributed generation. IEEE Transactions on Power Delivery. 2013 Oct; 28(4). <https://doi.org/10.1109/TPWRD.2013.2253808>
  13. Pavani P, Singh SN. Reconfiguration of radial distribution networks with distributed generation for reliability improvement and loss minimization. 2013 IEEE Conference of IEEE Power and Energy Society General Meeting; 2013.
  14. Zhao H-S, Zhao H-Y, Deng S. Reliability evaluation for distribution system connected with distributed generations. 2014 International Conference on Power System Technology (POWERCON 2014); Chengdu. 2014. Oct 20–22. <https://doi.org/10.1109/POWERCON.2014.6993754>
  15. Waseem I, Pipattanasomporn M, Rahman S. Reliability benefits of distributed generation as a backup source. 2009 IEEE Power and Energy Society General Meeting. <https://doi.org/10.1109/PES.2009.5275233>
  16. Chiradeja P. Benefit of distributed generation: A line loss reduction analysis. 2005 IEEE/PES Transmission and Distribution Conference and Exhibition: Asia and Pacific Dalian; China. 2005. <https://doi.org/10.1109/TDC.2005.1546964>
  17. Pahwa S, Weerasinghe D, Scoglio C, Miller R. A complex networks approach for sizing and siting of distributed generators in the distribution system; 2013 North American Power Symposium 2013.
  18. Keane A. Integration of distributed generation [PhD Dissertation]. Dublin: The University College; 2007 Jan.