

Analysis of short circuit faults in DFIG and PMSG wind farms

Shripad G Desai*, D S Bankar**and Vishal V Mehtre***

Transients in power system pose severe threat to the operation and control mechanism. various abnormal conditions categorized under short circuit faults have adverse effects on the system operation. Short circuit faults namely a single L-G fault and 3- Φ short circuit faults are to be given major importance to ensure reliability of the overall system. It is well known that these short circuit faults rather symmetrical or unsymmetrical are to be cleared as soon as possible. The clearing time of these fault currents is of major importance and emphasis has to be given on generator types which are capable of clearing such faults in a quick time. The paper focuses on two concerned generator's mainly used in the wind energy sector namely a DFIG type and the PMSG. Both these WTG (Wind Turbine Generator) topology are analysed for their short circuit capability in terms of impact of short circuit faults, time for recovery after occurrence of short circuit fault and for system oscillations if any.

Keywords: DFIG, PMSG, short circuit, wind farm

1.0 INTRODUCTION

Renewable sources of energy are looked upon as dominant solution for the rising energy demand. Renewable sources like the wind and solar have proved their dominance in the renewable sector. The rapid depletion of the fossil fuels like the coal used in the thermal power plants, diesel, petrol and uncertainty of rains posing threat to the hydro power plant, lead to focus on the renewable energy sources. Renewable sources also are superior due to its non-polluting nature and as they form ever lasting source of energy. Today the developing countries like India are strongly focused on the renewable sources like solar and wind, which was also presented by the Indian Prime Minister and Indian delegates at the Paris climate summit of December 2015. Today almost 11.84% of India's energy demand is met by the

renewables. Amongst the renewable sources wind takes a share of around 73.98% which proves its efficiency and reliability [1-2].

Although wind energy is an established resource for power generation still, there are various abnormality's which are to be strictly analyzed for high system reliability. Short circuit faults categorized as 3- Φ fault and single L-G fault are to be analyzed for their impact, recovery time and behavior. Short circuit fault in the system lead to issues like the synchronization issues which is a major issue in front of power system engineers [3]. Short circuit faults lead to voltage dips and further lead to stability issues in the power system [4]. Short circuit currents is to be given prime importance as they further lead to reduce the equipment life [5]. After the occurrence of the fault certain preventive measures are to be

*Student M.Tech-Electrical (Power Systems), Bharati Vidyapeeth Deemed University College of Engineering, Pune 411 043, shripad.d007@gmail.com , +91- 8551037897

**Associate Professor, Electrical Department, Bharati Vidyapeeth Deemed University College of Engineering, Pune 411 043, dsbankar@bvuocep.edu.in

*** Student M.Tech-Electrical (Power Systems), Bharati Vidyapeeth Deemed University College of Engineering, Pune 411 043, vishalmehetre7@gmail.com

adopted or else may lead to failure of the grid converters or high currents in the rotor of the generators [6]. The impact of the short circuit currents can be limited but it needs installation of current limiting devices which further add to the cost of the overall system [7]. Short circuit faults not only rise because of external conditions but also due to failure of insulation or high thermal stresses [8].

The objective of this paper is to demonstrate the capabilities of the considered DFIG and PMSG wind farm for its short circuit capability. The research primarily focuses on two concerned faults namely the 3- Φ short circuit fault and the single L-G fault. The analysis also covers the time required for the system to recover after the occurrence of the fault. The research also investigates for any system oscillation after fault clearance. All these conditions are analyzed for both the PMSG and DFIG wind farms and a comparative study amongst both is performed. The superiority between the DFIG and PMSG is demonstrated by performing the short circuit study in the power system simulation tool ETAP (Electrical Transient Analyzer Program). The research work is primarily focused to present a generator with superior Short circuit limiting and recovering capability.

In the paper [3] the authors present the issues after occurrence of any short circuit fault leading to synchronization issues and power system stability. In paper [4] the authors present adverse effects of short circuit faults on the DFIG machines. The authors in paper [5] indicate that if the short circuit current is to be limited use of current limiting device is to be made, also the impact of these currents should be minimal to protect the equipment and enhance its life. They also add that if use of current limiting device is made it adds to its overall cost, hence a wind generator with good short circuit limiting capability is to be preferred. In paper [6] the authors have analyzed both the symmetrical and unsymmetrical fault in the DFIG machines and discussed about its impact.

2.0 WIND FARM UNDER CONSIDERATION

The same wind farm with similar operating topology was considered for both PMSG and DFIG wind farm. Both the wind farms were individually investigated for their short circuit studies with similar operating conditions. The type of generators being different all other parameters were kept the same. All the analysis was done at rated wind speed of 13 m/s. The wind farm consisted of total of 13 WTG's of 2.1 MW each. Thus the wind farm contributed a total of 27.3 MW. The WTG's consisted of a transformer unit of 2500 kVA to step up the generating voltage of 0.69 kV to 33 kV. The Two main transformers in the wind farm (T1 and T2) are used to raise voltage level to 132 kV from 33 kV. The WTG specification includes a 3- Φ , 2.1 MW, 0.69 kV, 1500 rpm induction and synchronous generator accordingly with stator resistance of 2.83 Ω , assigned in ETAP. The design was as per the proposed wind farm for consideration in future. The layout of the wind farm is presented in Figure 1 below.

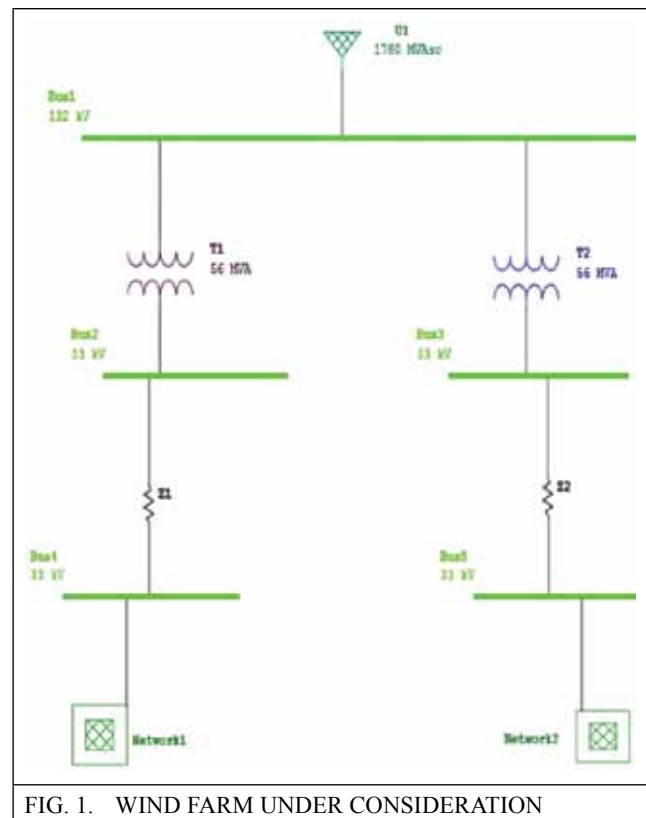

FIG. 1. WIND FARM UNDER CONSIDERATION

3.0 WIND TURBINE GENERATOR'S

The considered wind farm was analyzed for short circuit study for both the WTG's initially the PMSG and later on the DFIG wind farm. The PMSG stands for permanent magnet synchronous generator. It is connected to the grid through converters presented in Figure 2 below. It consists of a generator, dc capacitor, converter unit and transformer unit. The grid side converter is used to maintain the sending end voltage, whereas for optimal power transmission stator side converter is used. The PMSG topology has lower initial cost, capable of operating in various frequency range, and overall high efficiency.

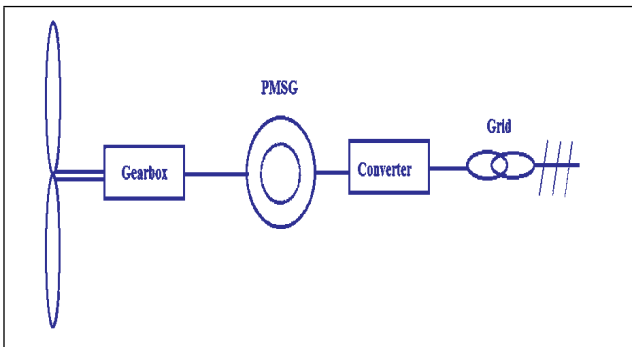

FIG. 2. SCHEME OF PMSG SYSTEM

The DFIG topology (Doubly Fed Induction Generator) has both its stator and rotor connected to the grid. The DFIG system makes use of back to back Power converters. The outstanding feature of such machines being its capability of giving reactive power to the grid. Although they are highly efficient but still need frequent maintenance, frequent to faults, high cost and more use of power electronic devices. The scheme for the DFIG system is presented in the Figure 3 below with a set of blades, gearbox and converter units.

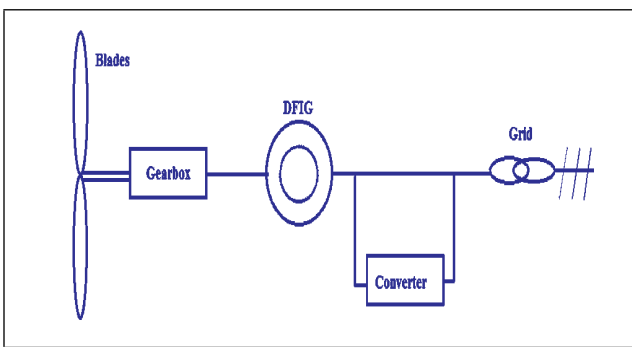

FIG. 3. SCHEME OF DFIG SYSTEM

4.0 RESULTS AND ANALYSIS

4.1 Single L-G Fault

The Un-Symmetrical fault in terms of single line to ground fault is the most occurring fault in the system [9]. The single L-G fault is to be analysed for its impact on the considered wind farms. Initially the single L-G fault was introduced on the PMSG wind farm at Bus 1 nearer to the grid at 7 seconds and cleared at 7.2 seconds, the simulation was analysed for a total of 15 seconds. It was found that during the presence of the fault in the PMSG wind farm the voltage dip to almost 84.76 kV during the presence of the fault. The voltage dip during the presence of fault is presented in Figure 4 below.

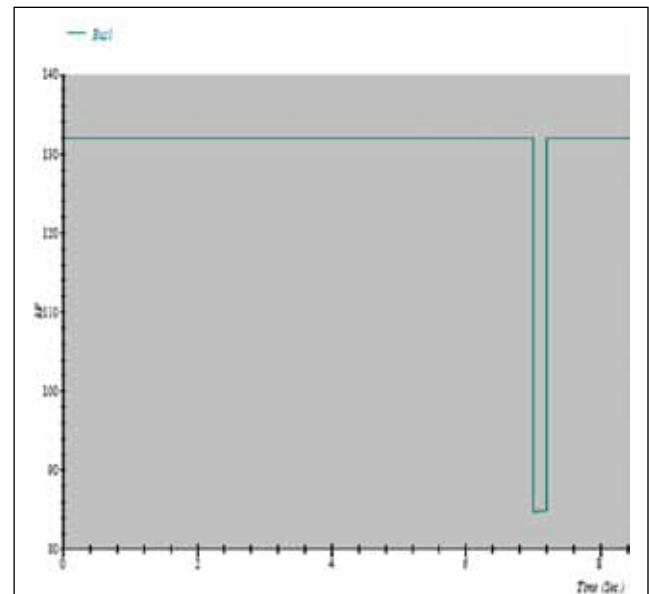

FIG. 4. SINGLE L-G FAULT AT BUS 1 ON PMSG SYSTEM

It can be clearly observed from the simulation result that the voltage dip to almost 84.76 kV. Also it is observed that after the fault clearing at 7.2 seconds the system voltage started recovering, with 100% system voltage of 132 kV being observed at 7.201 seconds. The tabular form of system recovery voltage with respect to time is presented in Table 1 below. It is also observed that after the fault clearing the system did not face any oscillations and thus achieved stability. After the fault clearing at 7.2 seconds the system totally recovered at 7.201 seconds to 132.031 kV.

TABLE 1 VOLTAGE RECOVERY IN PMSG FOR SINGLE L-G FAULT		
SL. NO.	TIME AFTER FAULT CLEARING (SECONDS)	SYSTEM RECOVERY VOLTAGE (KV)
1	7.001	84.7688
2	7.181	84.7893
3	7.201	132.031
4	7.301	132.026
5	7.401	132.025
6	7.501	132.025
7	7.581	132.025

Now the DFIG wind farm was considered for its short circuit study at Bus 1 with similar operating conditions like the PMSG. Where the fault was introduced at 7 seconds and cleared at 7.2 seconds with a total simulation time of 15 seconds. It was observed that in the DFIG wind farm during the presence of the single L-G fault the voltage dip to almost 83.84 kV which was more than that of the PMSG. Also it was observed that in the DFIG system the voltage recovered to 100% of its 132 kV at 7.581 seconds which was again more than the time taken by the PMSG wind farm. The simulation result of the DFIG single L-G fault is presented in Figure 5 below with its system recovery voltage in the tabular form in Table 2. It was also observed that after the fault was cleared in the DFIG system there were severe oscillations leading to instability in the system.

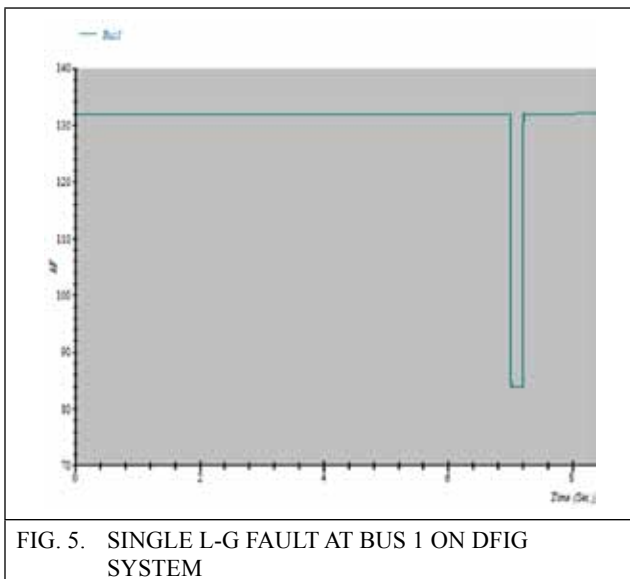

FIG. 5. SINGLE L-G FAULT AT BUS 1 ON DFIG SYSTEM

TABLE 2 VOLTAGE RECOVERY IN DFIG FOR SINGLE L-G FAULT		
SR. NO.	TIME AFTER FAULT CLEARING (SECONDS)	SYSTEM RECOVERY VOLTAGE (KV)
1	7.201	130.348
2	7.301	131.973
3	7.401	131.983
4	7.501	131.993
5	7.581	132.001
6	7.201	130.348
7	7.301	131.973

Thus the comparative study amongst PMSG and DFIG for short circuit study yields a promising result for the PMSG wind farm. Where in PMSG wind farm the voltage dip was less as compared to the DFIG wind farm, also the voltage recovery in the PMSG was quicker than the DFIG as presented in the Table 1 and Table 2 above. Also the DFIG system had fluctuations in voltage after the fault clearing thus indicating the voltage instability of DFIG wind farms.

4.2 3- Φ Short Circuit Fault

Short circuit fault between the 3- Φ is categorized as symmetrical fault and is one of the most severe fault in the system. The wind farm before commissioning and for short circuit study is to be properly analysed for 3- Φ short circuit fault. It is well known that short circuit increase the level of current and it rises to a very high value when it comes to 3- Φ fault.

The compatibility of the software makes the user analyse the short circuit faults. This time being a 3- Φ short circuit fault at Bus 1 for a total simulation time of 15 seconds. Again the fault was introduced at 7 seconds and cleared at 7.2 seconds. Initially the PMSG wind farm was considered, it was found that during the presence of the fault the system voltage collapsed to almost a 0 kV, indicating the significance of 3- Φ short circuit fault. The 3- Φ short circuit fault at Bus 1 for PMSG wind farm is represented in figure 6 below. Also the Table 3 below presents the system

recovery voltage in PMSG wind farm after the 3- Φ fault clearing. It can also be observed that after fault clearing there were no system voltage oscillations thus resembling short circuit handling capacity of the PMSG machines. It was observed that the system recovered to its total of 132 kV before 7.301 seconds.

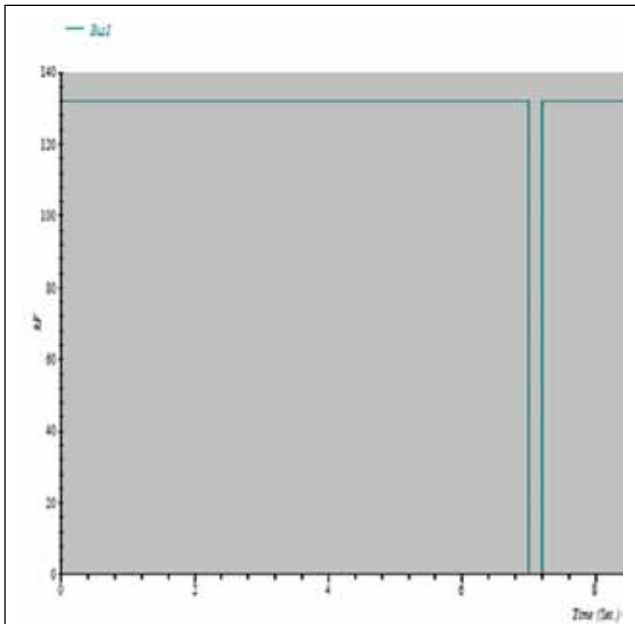

FIG. 6. 3- Φ SHORT CIRCUIT FAULT AT BUS 1 ON PMSG SYSTEM

TABLE 3		
VOLTAGE RECOVERY IN PMSG FOR 3- Φ SHORT CIRCUIT FAULT		
SR. NO.	TIME AFTER FAULT CLEARING (SECONDS)	SYSTEM RECOVERY VOLTAGE (KV)
1	7.201	131.924
2	7.221	131.994
3	7.301	132.039
4	7.241	132.018

Now the DFIG based wind farm was considered for its short circuit study. With the similar conditions like the PMSG, with the fault introduced at 7 seconds and cleared at 7.2 seconds with a total simulation time of 15 seconds. The Figure 7 below represents the 3- Φ short circuit fault on the DFIG wind farm. Here too the voltage dipped to almost a critical value of 0 kV. The Table 4 below

represents the voltage recovery in the DFIG wind farm after fault clearing.

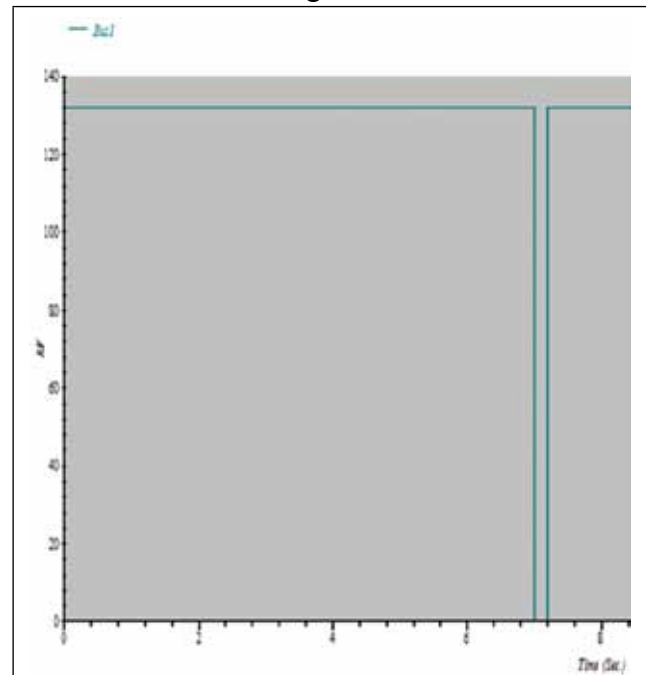

FIG. 7. 3- Φ SHORT CIRCUIT FAULT AT BUS 1 ON DFIG SYSTEM

TABLE 4		
VOLTAGE RECOVERY IN DFIG FOR 3- Φ SHORT CIRCUIT FAULT		
SR. NO.	TIME AFTER FAULT CLEARING (SECONDS)	SYSTEM RECOVERY VOLTAGE (KV)
1	7.201	131.896
2	7.221	131.987
3	7.301	132.028
4	7.241	132.018

Although 3- Φ short circuit for both DFIG and PMSG resemble a similar characteristics but still the voltage recovery was faster in the PMSG wind farm as compared to the DFIG wind farm.

4.3 Single L-G Fault at the WTG

Initially after the analysis at the grid side, now the single L-G fault was analysed at Bus 12 of the WTG in network 1 for a total simulation time of 20 seconds. The WTG located at Bus 1 is presented in the Figure 8 below, the operating voltage of the Bus being 0.69 kV. Only single

L-G fault was considered here as it is the most occurring fault in the system as mentioned earlier.

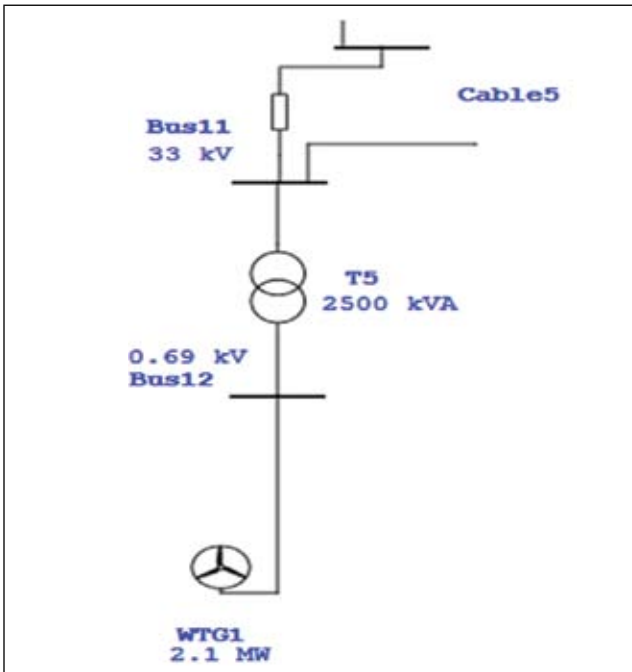

FIG. 8. SINGLE L-G FAULT AT BUS 12 OF WTG 1

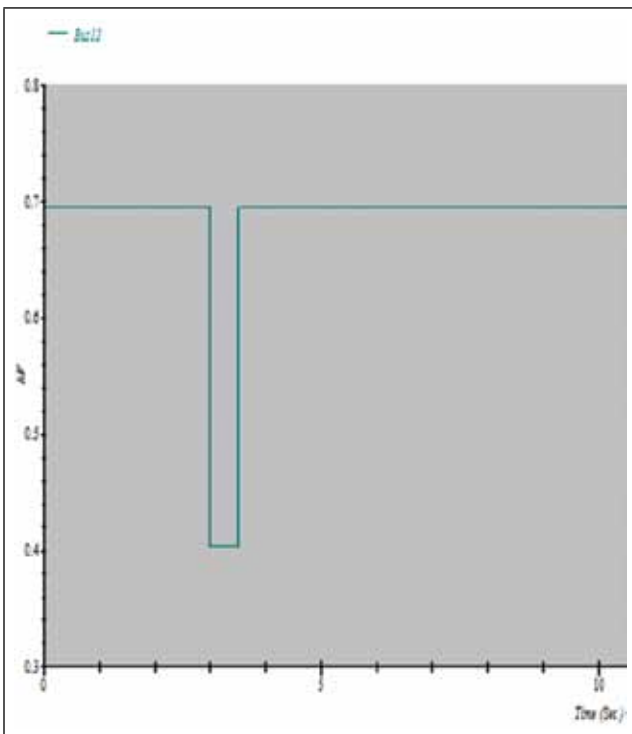

FIG. 9. SINGLE L-G FAULT ANALYSIS AT WTG1 IN PMSG WIND FARM

Initially the PMSG wind farm was considered for transient analysis with the event created at Bus 12 near the WTG 1. The operating voltage of the Bus being 0.69 kV, during the presence of the

fault the system voltage collapsed to a minimal of 0.4037 kV during the presence of fault. The single L-G fault for the PMSG at the WTG side is represented in Figure 9 below with the voltage recovery of the system in Table 5.

TABLE 5		
VOLTAGE RECOVERY IN PMSG FOR SINGLE L-G FAULT AT WTG1		
SR. NO.	TIME AFTER FAULT CLEARING (SECONDS)	SYSTEM RECOVERY VOLTAGE (KV)
1	3	0.69
2	3.001	0.4037
3	3.101	0.4040
4	3.5	0.404
5	3.501	0.69301

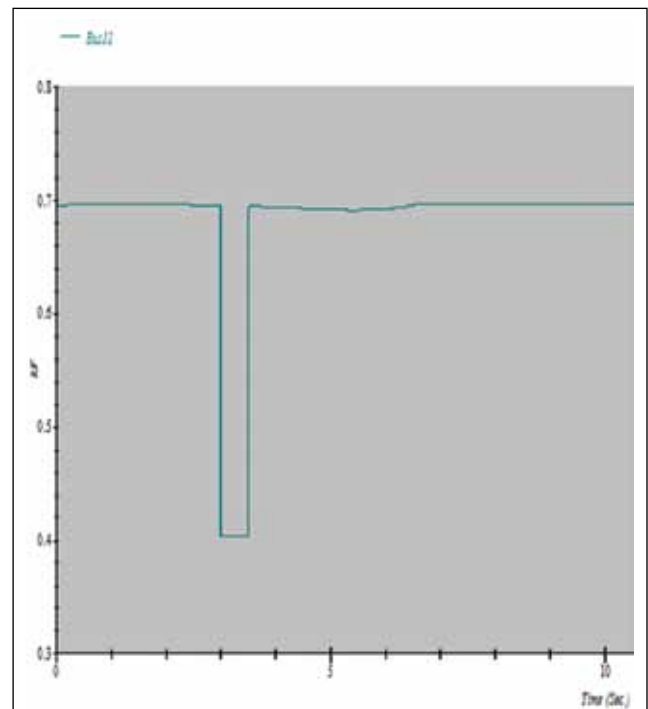

FIG. 10. SINGLE L-G FAULT ANALYSIS AT WTG1 IN DFIG WIND FARM

Now the similar conditions were implemented for the DFIG wind farm with fault introduced at 3 seconds and cleared at 3.5 seconds. It was observed that in the DFIG wind farm at Bus 12 near WTG 1, the voltage collapsed to almost 0.4037 kV again. It was also found that after the

fault clearing at 3.5 seconds there were frequent oscillations in the system which is also represented in Figure 10 below. The Table 6 gives the voltage recovery in the Bus 12 for DFIG system.

TABLE 6		
VOLTAGE RECOVERY IN DFIG FOR SINGLE L-G FAULT AT WTG1		
Sr. No.	Time after Fault Clearing (seconds)	System Recovery Voltage (kV)
1	3	0.6946
2	3.001	0.4037
3	3.101	0.4037
4	3.5	0.4037
5	3.501	0.6924

5.0 CONCLUSIONS

- 1) Thus the comparative study between the two wind farms gives a superior short circuit capacity for the PMSG wind farms as compared to the DFIG wind farms.
- 2) Although the characteristics were quite similar for 3- Φ faults but considering single L-G fault, PMSG provided very fruitful results.
- 3) In the PMSG wind farm the voltage dip was less as compared to the DFIG wind farm. Also the PMSG machines after fault clearing were stable with no voltage oscillations. Whereas DFIG machines had frequent Voltage oscillations after fault clearing indicating its incapability in handling the short circuit faults and leading to instability in the system.
- 4) Short circuit faults cannot be ignored they will occur in the system, but selection of the best suitable WTG's to handle such short circuits can be decided by the user using a simulation tool. Thus a comparative study yields promising results for the PMSG wind farm considering its superior short circuit handling capacity.

FUTURE WORK

- Reduce the level of short circuit currents by application of Series Reactor.
- Short circuit analysis on other WTG types.

REFERENCES

- [1] WWEA- World Wind Energy Association retrieved from <http://www.wwindea.org/hyr/2015/>
- [2] Report of Government of India, Ministry of Power, Central Electricity Authority, New Delhi, March 2015, retrieved from http://cea.nic.in/reports/monthly/executivesummary/2015/exe_summary-03.pdf
- [3] R J Best, D J Morrow and P ACrossley, Current transients in the small salient-pole alternator during sudden short-circuit and synchronisation events, in IET Electric Power Applications, Vol. 4, No. 9, pp. 687-700, Nov. 2010.
- [4] A Nayir, E Rosolowski and LJedut, Analysis of short circuit faults in a system fed by wind turbine, Renewable Energy Research and Applications (ICRERA), 2012 International Conference on, Nagasaki, pp. 1-4, 2012.
- [5] H Li, A Bose and Y Zhang, On-line short-circuit current analysis and preventive control to extend equipment life, in IET Generation, Transmission & Distribution, Vol. 7, No. 1, pp. 69-75, Jan. 2013.
- [6] Z P Wei, T Zheng and J Li, Short circuit current analysis of DFIG with crowbar under unsymmetrical grid fault, Renewable Power Generation Conference (RPG 2013), 2nd IET, Beijing, pp. 1-4, 2013.
- [7] L Jiang, J Y Liu, Z B Wei, C Chen, B Masoud and W X Liang, An integrated short-circuit current limiting scheme for Sichuan 500kV power grid considering Xinjiang power injection, Power System Technology (POWERCON), 2014 International Conference on, Chengdu, pp. 294-299, 2014.

- [8] P Arumugam, T Hamiti and C Gerada, Turn–turn short circuit fault management in permanent magnet machines, in IET Electric Power Applications, Vol. 9, No. 9, pp. 634-641, 2015.
- [9] M Kheshti, X Kang, G Song and Z Jiao, Modeling and Fault Analysis of Doubly Fed Induction Generators for Gansu Wind Farm Application, in Canadian Journal of Electrical and Computer Engineering, Vol. 38, No. 1, pp. 52-64, Winter 2015.